



MEMORANDUM

TO: Laura Fitzpatrick, Chairperson
Economic and Community Development Committee

FROM: Jennifer Ganser, Assistant Director of Community Development *JG*

DATE: November 25, 2013

SUBJECT: Downtown Improvement & Renovation Grant; 15 N. Main Street (MaidPro)

The Community Development Department has received an application for the Downtown Improvement and Renovation Grant Program (also known as the Facade Grant Program) for MaidPro located at 15 N Main Street. The applicant is seeking to install a new channel letter sign, as depicted on the attached plans.

GRANT REQUEST

The tenant is seeking to install a new sign. The applicant has submitted three bids for the proposed work:

Vendor	Price Quote
Fast Signs	\$3,380
Aubrey Sign Co.	\$2,550
Olympic Signs	\$3,995

The proposed sign is a front-illuminated with channel letters. The proposed sign varies in square footage depending on the vendor and all three would be in compliance with the Sign Ordinance.

Based on the lowest bid, the applicant is eligible to receive up to \$1,275.00 from the Improvement and Renovation Grant program. This request is under \$10,000 and therefore it does not require approval from the Board of Trustees and can be approved by the ECDC.

Staff is not supportive of the request for the following reasons:

1. Inconsistent with the recommendations of the Lombard Downtown Revitalization Project Guidebook
2. Inconsistent with past approval for other façade grant requests
3. Agrees with attached letter from Lombard Town Centre Design Committee

Lombard Downtown Revitalization Project Guidebook focuses on aesthetic standards in Section 4. The design recommendations can be applied to numerous buildings in downtown Lombard. Recommendations include buildings with fabric awnings containing signage and gooseneck lighting, and buildings with fabric awnings, gooseneck lighting, and signage above.

November 25, 2013
15 N Main Street
Page 2

It should be noted that all grant requests paid for by Village of Lombard TIF dollars shall comply with the Illinois Prevailing Wage Act. Therefore, if the grant is approved, the applicant and property owner shall sign an acknowledgement form indicating that they are aware that this project is subject to prevailing wages.

COMMITTEE ACTION REQUESTED

This item is being placed on the November 25, 2013 ECDC agenda for consideration. Staff recommends that the request be denied as it is not consistent with the recommendation set forth within the Lombard Downtown Revitalization Guidebook.

H:\CD\WORDUSER\EDADM\ECDCMTE\Facade Grants\15 N. Main Street\ECDC memo.docx



October 30, 2013

George Jorgji
Maid Pro
15 N Main Street
Lombard, IL 60148

Dear Mr. Jorgji:

The Village of Lombard requested that the Lombard Town Centre Design Committee review your business' signage grant application. Our review process determines if proposed signs comply with the aesthetic guidelines outlined in the *Lombard Downtown Revitalization Project Guidebook (LDRPG)*, approved by the Village Board on March 23, 2011.

After conducting our review of your application, we cannot support funding the currently proposed sign with Village grant funds because we feel it does not comply with the façade enhancement guidelines in the LDRPG. We recommend you revise the design to eliminate a raceway-mounted internally-lit channel letter sign and, instead, utilize awning graphics and/or non-internally illuminated sign panels with gooseneck style lighting in order to obtain LTC support for your grant request.

We recognize that there are other internally-illuminated channel letter signs in the downtown. However, none of these signs received Village grant funding. LTC feels strongly that any improvement projects that receive grants from our TIF funds comply with the spirit of the LDRPG.

Should you have any questions, an electronic copy of the LDRPG can be downloaded from the Village website at: (www.villageoflombard.org/documentcenter/view/11102). Please refer to *Section 4, Façade Enhancement Strategies* for further detail on the aesthetic standards we are trying to achieve in our downtown.

Sincerely,

A handwritten signature in black ink that reads "Thomas R. Runkle". The signature is written in a cursive style.

Tom Runkle
Lombard Town Centre
Design Committee Chair

**DOWNTOWN IMPROVEMENT AND RENOVATION GRANT
PROGRAM PRE-APPLICATION**

1. A. Building Address and Description: 15 N. MAIN ST LOMBARD
IL 60148
B. Property Identification Number: 06-08-100-009
C. Legal Description of Property: _____

2. A. Owners Name: SOCORRO SAWORSKI
B. Owners Address: 7861 FOUNDERS LANE
NAPLES, FL 34104
C. Phone (day time): (630) 699-8832

3. Current Tenant, Building Address, Lease Terms, and Description of Business: (use additional paper if necessary)
A. MAIDPRO - 15 N. MAIN ST LOMBARD, IL 60148
3YR LEASE - OFFICE LOCATION FOR RESIDENTIAL CLEANING BUSINESS
B. _____
C. _____

4. Proposed Improvements and Renovations: NEW BUILDING SIGN

5. Plans/Drawings prepared by:

A. Name: _____

B. Address: _____

C. Phone (day time): _____

D. Estimated Cost of the Improvement and Renovation: \$ 3800⁰⁰

6. Statement of Understanding.

A. The applicant (undersigned) agrees to comply with the guidelines and procedures of the Downtown Improvement and Renovation Grant Program and the specific design recommendation of the Director of Community Development.

B. The applicant must submit detailed cost documentation, copies of building permits, and all contractors waivers of lien upon completion of work.

C. The applicant, owners, and all contractors must comply with all federal and local regulations (see the attached list).

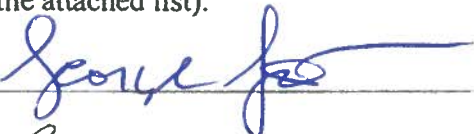
Business Owner Signature  (Date) 8/19/13

Property Owner Signature  (Date) 8/25/2013

Return application to:

Village of Lombard
Community Development Department
255 E. Wilson Ave., Lombard, IL 60148
630-620-5746



FASTSIGNS

318 E. Geneva Rd.
 Wheaton, IL 60187-2404
 ph: 630-221-1090
 fax: 630-221-1140
 Email: 592@fastsigns.com

Estimate

592 - 10556

Estimate Date: 9/4/2013 10:20:58AM

Printed: 10/4/2013 12:28:44PM

Salesperson: 592@fastsigns.com

Customer: Maid Pro ph: (630) 865-3593
Contact: George Jorgji **Customer:** 3903
Description: Channel Letters
Sales Person: David Spaeth
Clerk: David Spaeth email: gjorgji@maidpro.com

Dear George:

Thank you for choosing FASTSIGNS of Wheaton for your sign needs. The quotation we discussed is shown below. For Customer-submitted files, price includes 20 minutes to prepare files for printing. If more time is required the customer may resubmit the file or pay to prepare the files at \$125.00 per hour. Installation, permits, fees or licenses are not included in this estimate unless noted below. Installation charges are estimates only and are subject to change based upon actual times & expense. This estimate is valid for thirty (30) days from the estimate date shown above.

Sincerely,

David Spaeth
 Production Manager

	Product	Qty	Sides	H x W	Unit Cost	Totals
1	Special Orders Description: LED illuminated Channel Letter signage fabricated and installed.	1	1	48 x 144	\$3,380.00	\$3,380.00
2	Permitting Service Description: Fee to secure city/village permit NOT including the cost of the permit Customer MUST supply landlord's written approval for sign along with a site plan / architectural layout of building before applying for the permit. Work on the sign will NOT begin until the permit has been issued by the city/village.	1	1	1 x 1	\$250.00	\$250.00

Notes:

Line Item Total:	\$3,630.00
Tax Exempt Amt:	\$250.00
Subtotal:	\$3,630.00
Taxes:	\$245.05
Total:	\$3,875.05

Deposit Required: **\$3,875.05**

Bill To: Maid Pro
 George Jorgji
 15 N Main St
 Lombard, IL 60148

Payment due upon completion of order.

Received/Accepted By: / /

15

maidpro 



Estimate



Aubrey Sign Company
1847 Suncast Lane
Batavia, IL 60510
ph. (630) 482-9901
fax (630) 482-9906
email: aubreysigns@sbcglobal.net

Estimate: **ASC- 9113**
Printed 10/3/2013 12:14:22PM

Description: **Channel letters**
Prepared For: George Jorgji
Company: Maid Pro

ph: (630) 396-2195
fax: (630) 599-1135
email: gjorgji@maidpro.com

Dear George:

Thank you for contacting us regarding your signage needs. The estimate you've requested is below. We require a signed estimate and 50% deposit (or guarantee of payment) before we begin any formal artwork, design or production. When we have received your signed estimate and deposit, we will email you a color proof of your artwork for your approval. Production will not begin until we have your approval of the artwork and permit (if required) has been issued. If you have any questions, please do not hesitate to contact us.

Sincerely,

Mike Hoffer
President

Product	Font	Qty	Sides	Height	Width	Unit Cost	Install	Item Total
1 Channel Letters		1	1	28	90	\$1,850.00	\$700.00	\$2,550.00

Color: PMS Blues

Description: Front-illuminated, raceway mounted channel letters.
White plex faces with translucent vinyl overlays (match company PMS colors ACAP). White trim caps and returns.
Low voltage power supplies, external disconnect, UL listing.
Paint raceway to match brick facade ACAP.

Text: Maid Pro (logo -- per your supplied art file)

Estimate



Aubrey Sign Company
1847 Suncastr Lane
Batavia, IL 60510
ph. (630) 482-9901
fax (630) 482-9906
email: aubreysigns@sbcglobal.net

Estimate: **ASC- 9113**
Printed 10/3/2013 12:14:22PM

Notes:

A \$250 NON-REFUNDABLE DEPOSIT IS REQUIRED TO SUBMIT SHOP DRAWINGS TO THE VILLAGE OF LOMBARD FOR APPROVAL. THIS PAYMENT WILL BE APPLIED TO THE PROJECT TOTAL SHOULD YOU GO FORWARD WITH IT.

THIS QUOTE IS BASED UPON NORMAL INSTALLATION DURING REGULAR BUSINESS HOURS AND UNRESTRICTED ACCESS TO THE INSTALLATION SITE. ADEQUATE POWER MUST BE PROVIDED TO SITE OF SIGN INSTALLATION. ADDITIONAL CHARGES MAY APPLY.

THE PRICE OF YOUR SIGN DOES NOT INCLUDE ANY REQUIRED LICENSES, BONDS OR PERMITS – OR AUBREY SIGNS SURVEY AND PROCUREMENT FEE (\$150). THERE WILL AN ADDITIONAL CHARGE TO ATTEND ANY GOVERNMENTAL MEETINGS WHICH MAY BE NECESSARY TO OBTAIN PERMIT APPROVAL.

ANY ADDITIONS, DELETIONS OR OTHER CHANGES TO THIS ORDER BY CUSTOMER MAY RESULT IN A PRICE CHANGE OF ONE OR MORE LINE ITEMS – AND/OR THE INSTALLATION CHARGES.

OUR TERMS ARE FIFTY (50%) DOWN AT THE TIME THE ORDER IS PLACED AND THE ENTIRE BALANCE IS DUE WHEN THE ORDER IS PICKED UP OR INSTALLED.

ALL SIGNS, SIGN MATERIALS AND AWNINGS REMAIN THE PROPERTY OF THE AUBREY SIGN CO., INC. UNTIL THE ORDER HAS BEEN PAID FOR, IN FULL. CUSTOMER AGREES THAT, IN THE EVENT THAT THE INVOICE IS NOT PAID IN FULL WITHIN THE STATED PAYMENT TERMS, THE AUBREY SIGN CO. RESERVES THE RIGHT TO REMOVE/REPLACE THE SIGN OR AWNING.

THERE WILL BE A 3% SERVICE CHARGE FOR ANY CREDIT CARD PAYMENTS OVER \$500.

ANY INSURANCE REQUIRED IN ADDITION TO OUR STANDARD COVERAGE WILL INCURE ADDITIONAL CHARGES. THIS INCLUDES, BUT IS NOT LIMITED TO, REQUESTS FOR SPECIAL ENDORSEMENTS, ADDITIONAL INSURED, WAIVERS OF SUBROGATION, NON-CONTRIBUTORY COVERAGE OR BONDS.

CANCELLED ORDERS ARE SUBJECT TO A CANCELLATION PENALTY UP TO 100% OF THE DEPOSIT AMOUNT.

THERE WILL BE A \$100 CHARGE ON ANY PROJECT THAT REQUIRES A WAIVER OF LIABILITY.

Line Item Total:	\$2,550.00
Tax Exempt Amt:	\$700.00
Subtotal:	\$2,550.00
Taxes:	\$138.75
Total:	\$2,688.75

Deposit Required: **\$1,344.38**

Company: Maid Pro
15 N. Main Street
Lombard, IL 60148

Received/Accepted By: _____ / /

Channel Letters

Account:
Maid Pro

Location:
**15 N. Main St.
Lombard, IL**

Date: **10/2/13**

Projected Install Date:

THIS WORK REMAINS THE INTELLECTUAL PROPERTY OF THE AUBREY SIGN CO. UNTIL PAID FOR IN FULL BY CUSTOMER. USE OF THIS ARTWORK FOR ANY COMMERCIAL PURPOSE WITHOUT OUR WRITTEN PERMISSION WILL RESULT IN A \$1,000 PENALTY. PLEASE REVIEW, SIGN AND DATE THIS - INDICATING YOUR APPROVAL.

approved by _____ date _____

Aubrey
SIGN CO.
1847 Suncoast Lane
Batavia, IL 60510

Ph: 630-482-9901
Fax: 630-482-9906
www.aubreysigns.com

Email:
mike@aubreysigns.com

LED SIGN DETAIL (raceway mount)

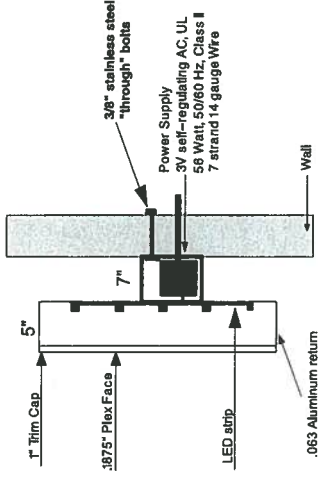

Sign details: Raceway mount, front illuminated channel letters, White plex faces with translucent vinyl overlays lays. White trim caps and returns.

Type of Illumination: White LEDs. Low voltage power supplies, UL Listing, External disconnect.

Dimensions: Overall 28" H x 90" W = 17.5 sq. ft.

Allowable sign limit:

Special Notes: Storefront = 17.5 ft. wide. Paint raceway to match brick facade ACAP. Electrical work by others.



1130 N. Garfield, Lombard, IL 60148
www.oly signs.com

PH: (630) 424-6100
FAX: (630) 424-6120

Contract
Page 1 of 2

Date 9-27-2013

Sketch # 13-5273

Dated 8-13

Sold To: Maidpro

Attn: George Jorgji

Billing Address: 15 N. Main St. Lombard, IL 60148

Phone: 630 865-3593

Location of Work: 15 N. Main St. Lombard, IL 60148

Fabricate and install 1- set of internally illuminated L.E.D. letters fabricated mounted on a raceway per drawing # 13-5273. Raceway will be flush mounted to building in approved location

Cost...\$3,995.00

Price excludes any and all permits required.

1. PRICE: \$ 3,995.00 TERMS: 1/2 (\$ 1,997.50) on signing, balance upon installation/delivery.

TAXES: Price includes applicable taxes.

PERMITS: Price does not include permits or permit acquisition costs. Olympic Signs shall, at Buyer's expense, obtain necessary permits and licenses from public authorities for the initial installation of the display(s).

FEED WIRES: If this agreement includes installation of an illuminated display, Buyer shall provide service feed wires of suitable capacity and approved type to within five (5) feet of the display(s) in advance of the installation date and Olympic Signs will make the final connection thereof to the display(s). Buyer to arrange for the providing and installing of any transformers, meters, timers or concrete pads at site.

DELIVERY AND PERFORMANCE: Olympic Signs will commence work upon receipt of accepted agreement, deposit, permits and licenses. The time for Olympic Signs performance is estimated, but is not guaranteed and is subject to delay resulting from war, fire, adverse weather, strike, acts of God, governmental regulations or other causes beyond reasonable control.

THIS AGREEMENT, INCLUDING TERMS AND CONDITIONS ON THE BACK OF THIS PAGE, CONSTITUTES THE ENTIRE UNDERSTANDING BETWEEN THE PARTIES. This agreement shall not take effect until signed on behalf of Buyer and by an officer of Olympic Signs. Buyer acknowledges receipt of a copy of this agreement and waives notification of acceptance hereof by Olympic Signs.

ACCEPTED:

OLYMPIC SIGNS, INC.

Buyer: _____

By: Robert Whitehead

Signature: _____

Date: 9-27-2013

Title: _____

Date _____

Prices subject to change if not accepted within thirty (30) days of above date.

TERMS AND CONDITIONS OF PURCHASE AGREEMENT

2. **FIELD CONDITIONS:** This agreement is based on standard installation conditions and does not take into consideration any non-standard soil conditions, installations at inaccessible areas, non-standard building conditions, etc. Quotations for installing items onto structures supplied by the Buyer are based on the assumption that the structures furnished by Buyer are structurally sound for accepting the display(s) purchased hereunder without modification. Exterior or interior building rework required to support signs is not included in our Agreement, unless so noted. If the installation requires that plates be placed on the inside of a wall, roof or ceiling, Olympic Signs agrees to perform this work in a workmanlike manner and Buyer agrees to pay for all plastering, redecoration or remodeling the Buyer may desire, unless otherwise specified in this agreement. For remoting of transformers, it is assumed that sufficient access to and behind wall for workmen will be provided by Buyer. Olympic Signs will patch roof or roof covering removed or opened by Olympic Signs during the installation of display, but in making such repairs Olympic Signs assumes no responsibility for rebonding. Olympic Signs shall be responsible for locating and clearing any underground public utilities on the site which affect or obstruct the Work. The Buyer is responsible for informing Olympic Signs of any private underground obstructions (such as sprinkler systems) which may affect or obstruct the Work.
3. If display has been erected but Olympic Signs has not completed the electrical connections due to the failure of Buyer to furnish service wiring as provided in this agreement, the balance of the purchase price shall be deemed due and owing.
4. **PERMITS, LICENSES:** Olympic Signs shall obtain all permits, cost to be borne by Buyer, from public authorities for the initial installation of display(s). Buyer shall be responsible for securing and furnishing all private permission necessary from the owner and any mortgagee of the premises upon which display is to be installed. Unless otherwise directed in writing by Buyer, Olympic Signs shall not commence fabrication of the display until all required public permits have been issued. If public permits are denied, then this agreement shall terminate without liability to either party; provided, however, that Buyer shall reimburse Olympic Signs for any permit application costs and any manufacturing costs incurred as a result of prior written direction by Buyer.
5. **TAXES:** Buyer shall pay all personal property, sales, use and other taxes which may be imposed by law on the display or the use thereof. Buyer shall reimburse Olympic Signs for any taxes that may be billed to and paid by Olympic Signs for display.
6. Olympic Signs agrees to have all their workmen covered by Worker's Compensation Insurance ; and further agrees to carry public Liability Insurance covering injuries to or death of persons and damage to property as a result of accidents for which Olympic Signs is responsible-subject to a single limit of \$1,000,000.00 each occurrence. Buyer shall indemnify and hold Olympic Signs harmless against any and all claims which may be asserted against Olympic Signs by reason of negligence of the Buyer, its agents, employees, or third parties. Insurance Certificates will be furnished to Buyer upon request.
7. Buyer bears full responsibility for risk of loss or damage to the display after delivery thereof to the site.
8. Title to the display and any other material furnished pursuant to this Agreement shall remain in Olympic Signs until all amounts owing hereunder have been paid in full. Until such amounts have been paid in full, all property furnished hereunder shall be deemed personal property, severable and removable from any realty to which it is attached, and shall not be deemed a fixture or appurtenance to such realty.
9. Buyer may not assign this Agreement without the prior written consent of Olympic Signs.
10. **SELLER'S WARRANTIES:** Olympic Signs warrants to Buyer that any display purchased hereunder (excluding lamps as to which Olympic Signs makes no warranty) at the time of delivery or installation, will be free from defects of material and workmanship, and will be in accordance with specifications which are a part of this Agreement. Olympic Signs sole obligation under these warranties is limited to either repair or replacement, at Olympic Signs option, of a defective part or nonconforming display for which written claim is made within 90 days of delivery or installation. All other warranties, whether express or implied, are disclaimed. **Note:** All gaseous conductor tubes have an inherent tendency to change in color and light intensity proportionate to the period of use. Mercury filled tubing of any age is affected by cold weather. These are universal characteristics and not defects in manufacture. Replacement of operative tubes so affected is not part of this Agreement.
11. **DEFAULT:** The occurrence of any of the following events shall constitute a default hereunder: (a) Buyer fails to pay any amounts hereunder when due; (b) Buyer shall fail to perform or observe any other covenant of this agreement; (c) Buyer becomes insolvent or becomes a debtor in Bankruptcy. Upon the occurrence of a default, Olympic Signs may declare all amounts remaining unpaid hereunder to be immediately due and payable. In such event, Olympic Signs shall have the right to enter upon Buyer's premises and take possession of the display or render it inoperable, without any liability whatsoever to Buyer and without relieving Buyer of its obligations hereunder. In the event of a default hereunder, Olympic Signs shall be entitled to recover from Buyer all fees and expenses, including attorney's fees, incurred by Olympic Signs in enforcing its rights hereunder, including any costs incurred in removal of the display.
12. This Agreement shall be governed by and construed in accordance with the laws of the State of Illinois.
13. This Agreement sets forth the entire understanding between the parties regarding the subject matter hereof. The terms of this Agreement may not be terminated, amended, supplemented, waived or modified except in writing signed by Buyer and a duly authorized officer of Olympic Signs.

Customers signature _____

Date _____

3'-2 3/4"

1'-4"

maidpro

12'-0"

INDIVIDUAL INT. LED ILLUMINATED LETTERS & LOGO ON A RACEWAY

SIGN #1

SCALE: 1/2" = 1'-0"

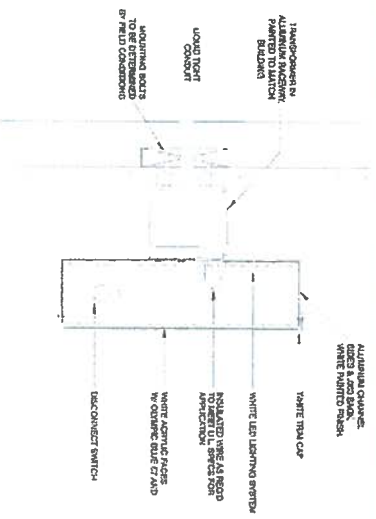

RACEWAY MOUNT INTERNALLY ILLUM. CHANNEL, LTD.



OLYMPIC SIGNS

1130 N. GARFIELD
 Lombard, IL 60148 Ph: 630.424.6100
 account representative Tom C. client

15 NORTH MAIN ST
 LOMBARD, IL 60148
 FX: 630.424.6120

WWW.OLYSIGNS.COM

THIS IS AN ORIGINAL, UNREPRODUCED DRAWING. SUBMITTING IN CONNECTION WITH A PROJECT MEANS AGREEMENT FOR THE USE OF THIS DRAWING. ANY REPRODUCTION OR DISTRIBUTION OF THIS DRAWING WITHOUT THE WRITTEN PERMISSION OF OLYMPIC SIGNS, INC. IS STRICTLY PROHIBITED BY LAW. ANY REPRODUCTION OR DISTRIBUTION OF THIS DRAWING WITHOUT THE WRITTEN PERMISSION OF OLYMPIC SIGNS, INC. IS STRICTLY PROHIBITED BY LAW.

page 1 of 1

job #: 13-5273
 8-13-13
 rev. # 8-13-13

Comments: _____
 Date: _____