

VILLAGE OF LOMBARD  
REQUEST FOR BOARD OF TRUSTEES ACTION  
For Inclusion on Board Agenda

  X   Resolution or Ordinance (Blue) \_\_\_\_\_ *Waiver of First Requested*  
  X   Recommendations of Boards, Commissions & Committees (Green)  
\_\_\_\_\_ Other Business (Pink)

TO: PRESIDENT AND BOARD OF TRUSTEES

FROM: Scott R. Niehaus, Village Manager

DATE: September 23, 2014 (B of T) Date: October 2, 2014

TITLE: Downtown Improvement & Renovation Grant; 130 E. St. Charles Road  
(Mesa Electronics)

SUBMITTED BY: Department of Community Development

BACKGROUND/POLICY IMPLICATIONS:

Your Economic and Community Development Committee (ECDC) transmits for your consideration its recommendation on the above referenced petition and a resolution approving a Downtown Improvement and Renovation Grant for the property commonly known as 130 E. St. Charles Road. (DISTRICT #4)

The ECDC recommended approval of this grant request by a vote of 5-0.

Fiscal Impact/Funding Source:

Review (as necessary):

Village Attorney X \_\_\_\_\_ Date \_\_\_\_\_

Finance Director X \_\_\_\_\_ Date \_\_\_\_\_

Village Manager X \_\_\_\_\_ Date \_\_\_\_\_

NOTE: All materials must be submitted to and approved by the Village Manager's Office by 12:00 noon, Wednesday, prior to the Agenda Distribution.



## MEMORANDUM

**TO:** Scott R. Niehaus, Village Manager

**FROM:** William J. Heniff, AICP, Director of Community Development *WJH*

**DATE:** October 2, 2014

**SUBJECT: Downtown Improvement & Renovation Grant; 130 E. St. Charles Road (Mesa Electronics)**

Please find the following items for Village Board consideration as part of the October 2, 2014 Board meeting:

1. Economic and Community Development Committee (ECDC) memo; and
2. A Resolution Approving a Downtown Improvement and Renovation Grant for the Property Commonly Known As 130 E. St. Charles Road.

The Community Development Department received an application for the Downtown Improvement and Renovation Grant Program (also known as the Facade Grant Program) for 130 E. St. Charles Road. The Applicants are seeking to install awnings, electric and gooseneck lighting, a decorative fence, and masonry work. The property is located in TIF 1 West. The total cost of project is \$97,003.89 and is grant eligible up to \$48,501.95 (up to 50% of the eligible project costs; not to exceed \$50,000, unless specifically approved by the Village Board). Said recommendation is subject to the following conditions, by the Village Board of Trustees, that would be in effect if the property was sold or retains its current ownership:

1. Expenditures relative to the Project must comply with the Illinois Prevailing Wage Act;
2. Permits must be applied for and received for all of the work;
3. Before the grant can be paid out, the Applicants will submit a final receipt (showing it is paid in full) and waivers of lien from the contractors; and
4. That the Applicants shall not apply for a vacancy exemption from the York Township Assessor during the ten (10) year period following receipt of the Grant.

The ECDC recommended approval of this grant request by a vote of 5-0. Please place this grant request on the October 2, 2014 Board of Trustees agenda.



## MEMORANDUM

**TO:** Trustee Laura Fitzpatrick, Chairperson  
Economic and Community Development Committee

**FROM:** Jennifer Ganser, Assistant Director of Community Development

**DATE:** September 8, 2014

**SUBJECT:** Downtown Improvement & Renovation Grant; 130 E. St. Charles Road  
(Mesa Electronics)

The Community Development Department has received an application for the Downtown Improvement and Renovation Grant Program (also known as the Facade Grant Program) for Mesa Electronics located at 130 E. St. Charles Road. The applicant is seeking to install awnings, electric and gooseneck lighting, a decorative fence, and masonry work. The property is located in TIF 1 West. The total cost of project is \$97,003.89 and is grant eligible up to \$48,501.95 (up to 50% of the eligible project costs; not to exceed \$50,000, unless specifically approved by the Village Board).

Mesa Electronics (mesaelectronics.com) purchased the property at 130 E. St. Charles Road. The building, which was owned and occupied by DuPage Heating and Air Conditioning, is currently vacant, but Mesa Electronics intends to move their business into the building.

Both the interior and exterior of the building will be divided into sections – the westernmost portion will be for business to business electronics and trade sales activities. This component focuses upon their outreach to private and public institutions such as hospitals to meet their electronic needs. The middle section of the building will have a focus upon more retail and business consumer based electronics activities. The far eastern portion of the building will be a separate retail space – the applicant has represented that he will likely make it available as a separate retail establishment, which could be for an anticipated jewelry sales use. These business activities are permitted uses within the underlying B2 zoning district and the proposed exterior design is intended to transition the building's office/industrial appearance to provide for more of a retail aesthetic.

The Lombard Downtown Revitalization Project Guidebook focuses on aesthetic standards in Section 4. The design recommendations can be applied to numerous buildings in downtown Lombard. Recommendations include buildings with fabric awnings containing signage and gooseneck lighting, and keeping with the character of downtown Lombard. Though 130 E. St. Charles Road is in TIF 1 West, the Guidebook can still be applied to ensure renovations keep a similar look and feel in the downtown and nearby buildings. Page 30 (attached) of the Guidebook highlights the building at 130 E. St. Charles Road. Even though a grocery store is not the proposed tenant, the exterior elevations match with the Guidebook principles. Also, upon

further environmental remediation the lots to the east of the subject property could lead to more parking.

It should be noted that all grant requests paid for by Village of Lombard TIF dollars shall comply with the Illinois Prevailing Wage Act. Therefore, if the grant is approved by the Village Board of Trustees, the applicant shall sign an acknowledgement form indicating that they are aware that this project is subject to prevailing wages.

**GRANT REQUEST ELEMENTS**

Mesa Electronics has submitted concept building elevations that would be the subject of the grant request. Interior build-out of the space would not a part of this application. Below are the various components anticipated to be undertaken that would be eligible for façade grant consideration.

*Awnings*

Mesa Electronics is seeking to install three black awnings on the south elevation. The awnings will have white lettering and it is anticipated that the signage will meet code. Complete drawings showing the location and size of the text will be submitted for a permit and reviewed at that time. The applicant has submitted three bids for the proposed work and based on the lowest bid the applicant is eligible to receive up to \$3,910.00.

Vendor	Price Quote
B. H. Awning & Tent	\$8,190.00
Chesterfield Awning Co.	\$7,834.00
<b>Thatcher Oaks Inc.</b>	<b>\$7,820.00</b>

Staff is supportive of the request for the following reasons:

1. Consistent with the recommendations of the Lombard Downtown Revitalization Project Guidebook
2. Consistent with past approval for other façade grant requests

*Electric Service for External Illumination*

Mesa Electronics is seeking to install electric service for outside gooseneck lighting above the awnings. The applicant has submitted three bids for the proposed work and based on the lowest bid, the applicant is eligible to receive up to \$575.00.

Vendor	Price Quote
Alternating Currents Corp.	\$2,973.00
<b>Les Electric</b>	<b>\$1,150.00</b>
Von's Electric, Inc.	\$4,175.00

Staff is supportive of the request for the following reasons:

1. Consistent with the recommendations of the Lombard Downtown Revitalization Project Guidebook
2. Consistent with past approval for other façade grant requests

*Lighting*

Mesa Electronics is seeking to install outside gooseneck lighting above the awnings and sconces. The applicant has submitted three bids for the proposed work. Brook Electrical Supply and Steiner are quoting both types of lights. Sunshine Lighting only quoted the sconces and West Electric Supply only quoted gooseneck lighting. Steiner also quoted eight (8) lights that Mesa Electronics is not using. The price below for Steiner reflects that \$119.60 removed. Based on the lowest bid, the applicant is eligible to receive up to \$1,449.45.

Vendor	Price Quote
<b>Brook Electrical Supply</b>	<b>\$2,898.89</b>
Steiner	\$3,246.42
Sunshine Lighting and West Side Electric Supply	\$2907.70

Staff is supportive of the request for the following reasons:

1. Consistent with the recommendations of the Lombard Downtown Revitalization Project Guidebook
2. Consistent with past approval for other façade grant requests
3. The new lighting would create an aesthetic enhancement for the corridor

*Masonry*

Mesa Electronics is seeking to change and update the building façade on the south and part of the west elevations to include additional compatible masonry, and an enhanced parapet wall with EIFS construction. Four new window openings will be installed on the south elevation, consistent with a typical retail storefront. The new brick color will be matched to the current brick. The front entrance would be ADA accessible. The applicant has submitted three bids for the proposed work and based on the lowest bid the applicant is eligible to receive up to \$18,162.50.

Vendor	Price Quote
Midland Masonry	\$51,400.00
Soumar Masonry	\$67,900.00
<b>Superior Masonry, Inc.</b>	<b>\$36,325.00</b>

Staff is supportive of the request for the following reasons:

1. Consistent with the recommendations of the Lombard Downtown Revitalization Project Guidebook
2. The new exterior would create an aesthetic enhancement for the corridor

*Glass*

Mesa Electronics is seeking to install new windows on the south elevation. The applicant has submitted three bids for the proposed work and based on the lowest bid the applicant is eligible to receive up to \$17,500.00.

Vendor	Price Quote
<b>A &amp; G Glass &amp; Mirror, Inc.</b>	<b>\$35,000.00</b>
Carlson Glass	\$49,900.29
E & T Glass & Mirror, Inc.	\$47,089.00

Staff is supportive of the request for the following reasons:

1. Consistent with the recommendations of the Lombard Downtown Revitalization Project Guidebook
2. The new windows would be less reflective allowing the public to see into the storefronts.
3. The new windows would be more energy efficient than the current windows, as required by the State of Illinois Energy Code adopted by the Village.

*The North Exterior Perimeter Fence*

Mesa Electronics is seeking to install a new fence replacing the existing chain link fence on the property. The new fence will be a four feet tall ornamental style aluminum fence and which will help create an aesthetic enhancement for the corridor. The applicant has submitted four bids for the proposed work and based on the lowest bid the applicant is eligible to receive up to \$6,905.00.

Vendor	Price Quote
<b>Northern Illinois Fence, Inc.</b>	<b>\$13,810.00</b>
Northern Illinois Fence, Inc.	\$14,810.00
Complete Fence	\$15,800.50
Fox Valley Fence & Supply	\$16,005.96

Staff is supportive of the request for the following reasons:

1. Consistent with the recommendations of the Lombard Downtown Revitalization Project Guidebook
2. Ensures the removal of the current fence
3. The new fence would create an aesthetic enhancement for the corridor

*Conditions of Approval*

Staff proposes the following conditions be placed on the grant, if approved by the Village Board of Trustees. The conditions would be incorporated into a Resolution, subject to approval from the Village Board of Trustees.

1. The project must comply with the Illinois Prevailing Wage Act. Since the project will be partially funded by grant (from TIF 1 West) the project must comply with the Illinois Prevailing Wage Act.
2. Permits must be applied for and received for all of the work. Permits should be applied for with the Building Division and will be ready after the appropriate departments/divisions are able to sign off stating that the project meets code.
3. Before the grant can be paid out, Mesa Electronics will submit a final receipt (showing it is paid in full) and waivers of lien from the contractors. This ensures that the project is paid in full before the Village remits the grant funds.
4. That the applicant/property owner shall not apply for a vacancy exemption from the York Township Assessor. Though the building is currently vacant, Mesa Electronics does plan on occupying the space. By not applying a vacancy exemption, the Village will receive property taxes based on the total equalized assessed value (EAV) both before and after the improvements occur. Seeking an exemption would be contrary to the intent of providing a TIF incentive.

**COMMITTEE ACTION REQUESTED**

This item is being placed on the September 8, 2014 ECDC agenda for consideration. Staff recommends that the ECDC recommend approval to the Village Board for the requested Downtown Renovation and Improvement Grant being sought by Mesa Electronics for the property at 130 E. St. Charles Road. The project total is \$97,003.89 and is grant eligible up to \$48,501.95. As this request is over \$10,000, it requires final approval from the Village Board of Trustees. Said recommendation is subject to the following conditions, by the Village Board of Trustees:

1. The project must comply with the Illinois Prevailing Wage Act.
2. Permits must be applied for and received for all of the work.
3. Before the grant can be paid out, Mesa Electronics will submit a final receipt (showing it is paid in full) and waivers of lien from the contractors.
4. That the applicant/property owner shall not apply for a vacancy exemption from the York Township Assessor.

**DOWNTOWN IMPROVEMENT AND RENOVATION GRANT  
PROGRAM PRE-APPLICATION**

1. A. Building Address and Description: 130 E. St. Charles Street  
10,000 Sq. Ft. Commercial Building, 15 ft. high, brick facade  
B. Property Identification Number: 06-08-104-011  
C. Legal Description of Property: Lots 7 + 8 in Block 19  
Stone's Addition to Lombard
  
2. A. Owners Name: Enrique + Lori Mesa  
  
B. Owners Address: 411 S. 2<sup>nd</sup> Street  
St. Charles, IL 60174  
C. Phone (day time): (     ) 630-880-9443
  
3. Current Tenant, Building Address, Lease Terms, and Description of Business: (use additional paper if necessary)  
A. NONE  
  
B. \_\_\_\_\_  
  
C. \_\_\_\_\_
  
4. Proposed Improvements and Renovations: Completely renovate exterior;  
new brick/stucco facade, new windows/doors/lights,  
removal + replacement of awnings, new garage door  
where visible to pedestrians.



5. Plans/Drawings prepared by:

A. Name: Isaac Plumb, K2 Studio

B. Address: 329 W. 18<sup>th</sup> Street, #501  
Chicago, IL 60616

C. Phone (day time): 630-880-9443

D. Estimated Cost of the Improvement and Renovation: \$ \_\_\_\_\_

6. Statement of Understanding.

- A. The applicant (undersigned) agrees to comply with the guidelines and procedures of the Downtown Improvement and Renovation Grant Program and the specific design recommendation of the Director of Community Development.
- B. The applicant must submit detailed cost documentation, copies of building permits, and all contractors waivers of lien upon completion of work.
- C. The applicant, owners, and all contractors must comply with all federal and local regulations (see the attached list).

Business Owner Signature  (Date) 8/25/14

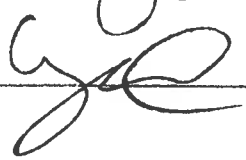
Property Owner Signature  (Date) 8/25/14

Return application to:

Village of Lombard  
Community Development Department  
255 E. Wilson Ave., Lombard, IL 60148  
630-620-5746

FIGURE 2A

**Site E1: Garfield/Maria Site**

**Description of Approach**

This site presently includes the former DuPage Heating & Air Conditioning site, as well as three vacant lots. To provide a local food market option for Downtown Lombard, a fresh market grocery is proposed for this site. Given the dimensions of the site, some of the parking would be provided on-site, while the remainder would be offered by on-street parking spaces. Loading for the grocery would occur at the rear. A screening fence along the rear (north) side of the site would provide a buffer between the grocery store and adjacent residential uses. The Metro commuter parking lot is located to the south across St. Charles Road.

**Site Data**

Site Area	38,293 sq ft (0.88 acres)
Parcels	4 parcels
Commercial	Fresh market grocery 15,000 sq ft (entire building)
Existing Uses	Former DuPage Heating & Air Conditioning site Three vacant lots

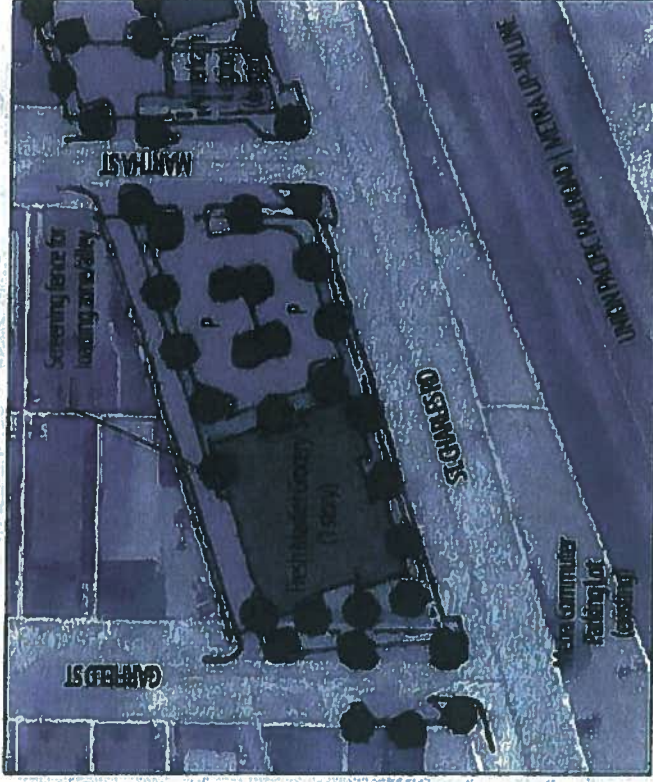

130 East Saint Charles Road  
Grant Proposal

It is our intention to take the vacant building at 130 East Saint Charles Road and turn it into a modern, elegant, anchor of the Saint Charles corridor. We hope that by replacing outdated features like the metal awning, chain-link fence, and decaying windows, and by updating the brick exterior, we will create an attractive addition to Lombard, one of which the community will be proud.



In terms of the exterior renovations, we would like to remove the dilapidated and un-insulated single-pane glass and replace it with windows and doors that are less reflective and highly efficient. By adding new windows, we seek to create a three-business storefront, each with its own entrance. One ADA accessible entrance would be at the corner of Garfield and East Saint Charles, and the other two would face East Saint Charles Road. The middle entrance would have a small ramp leading to the door, and the third entrance is already level with the sidewalk.

Currently, an outdated and badly oxidized chain-link fence surrounds the lot on three sides, lending the whole property the

aesthetic appeal of an industrial warehouse. To circumvent this, we plan on removing this outdated fence and replacing it with an attractive and understated fence of decorative steel that is 75% open and closed with an electronic gate. In keeping with this idea, we will be painting the existing overhead door that faces onto Garfield, again to give the entire building a more appealing and distinguished look.

Additionally, we would like to remove the antiquated metal awning and completely rehab that eastern facing facade. Not only would the metal awning be replaced with three new and modern awnings, but also we would be adding EIFS above them to give the building a more contemporary look. Four columns, constructed to closely match the existing brickwork, would serve the dual purpose of separating the storefronts and beautifying the overall structure, as seen in our rendering. The aforementioned canopies will be black with white lettering, and illuminated with new gooseneck lighting in keeping with downtown Lombard's preferred aesthetic. In order to bring added illumination to the East Saint Charles corridor, we would be adding four sconce lights on each of the columns. It is our hope to enhance the building and attract foot traffic both during the day and at night.

(Below is an additional rendering of our building, placed side by side with the one seen above in order to highlight details such as the awning placement and the lighting.)

---

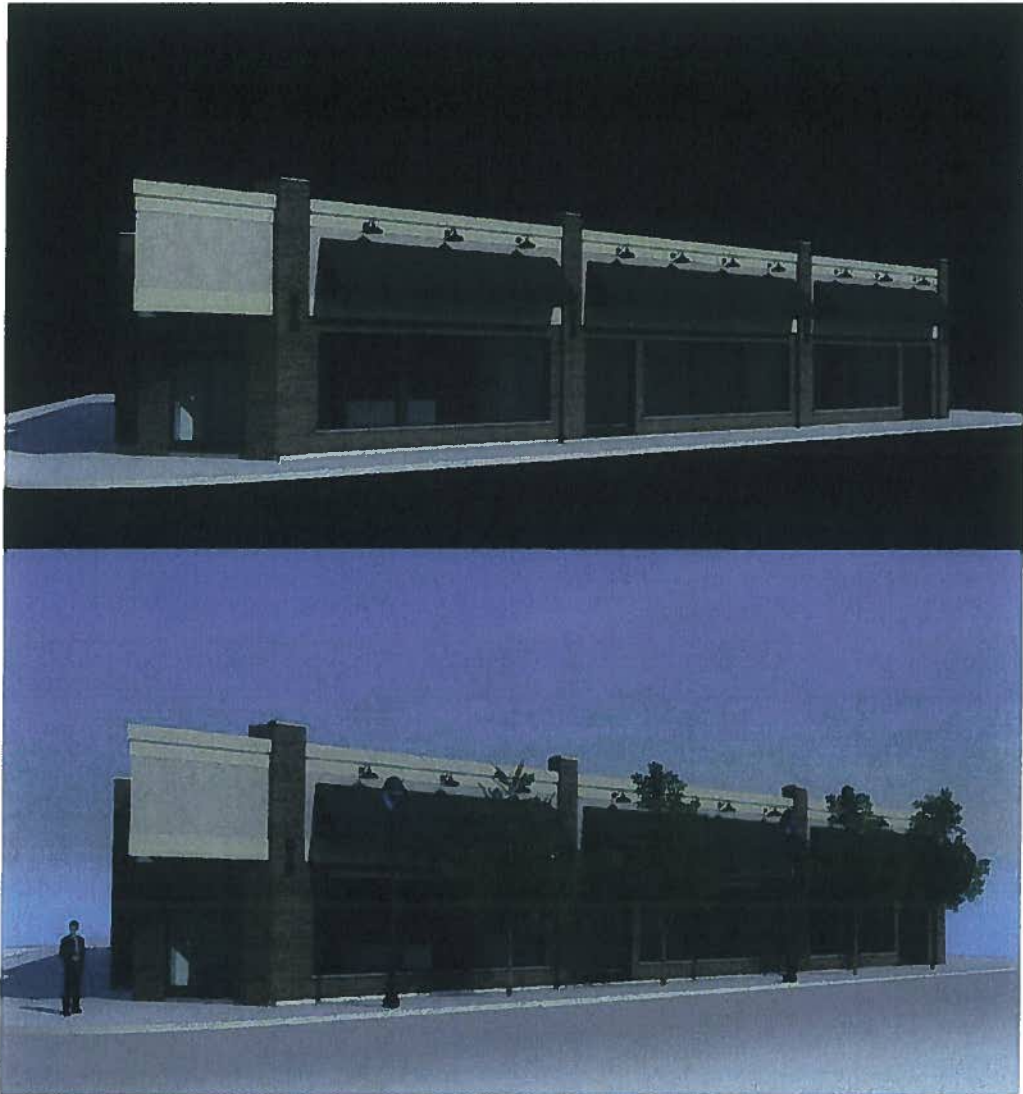

# MESA ELECTRONICS INC. EXTERIOR RENOVATION

MESA ELECTRONICS INC.  
130-134 E. ST. CHARLES ROAD  
LOMBARD, IL 60148

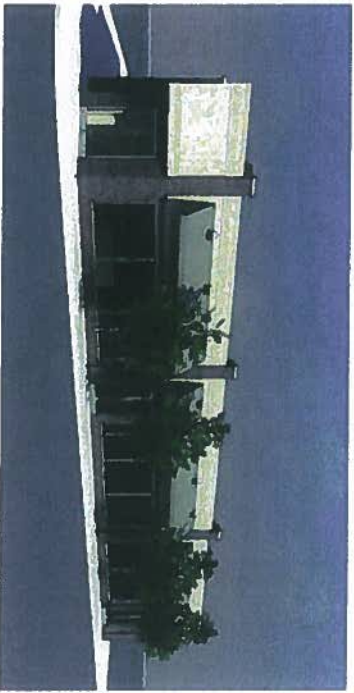

N. GARFIELD STREET

Sheet Number	Sheet List	Sheet Name
AE-001	COVER	
AE-101	FLOOR PLAN	
AE-201	EXTERIOR ELEVATIONS	
AE-301	WALL SECTIONS & DETAILS	
AE-302	SECTIONS AND DETAILS	
AD-101	DEMO PLAN	
AD-201	DEMO-ELEVATIONS	

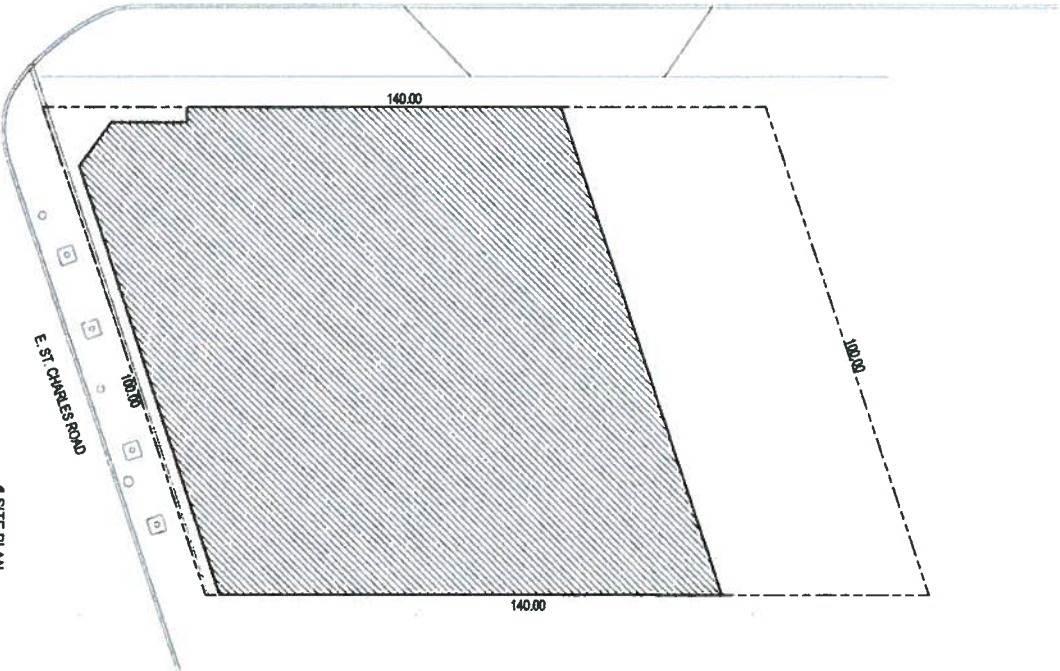

4 SITE PLAN

- EXTERIOR ELEVATION
- BUILDING SECTION
- INTERIOR ELEVATION
- DETAIL SECTION
- GROUND
- LEVEL - ARCHITECTURAL
- SPOT ELEVATION
- DETAIL CALLOUT
- CONCRETE
- CONCRETE REINFORCING
- STONE
- BRICK
- GLAZING
- WOOD
- ASPHALT
- PAVING
- LANDSCAPE
- ROOFING
- MECHANICAL
- ELECTRICAL
- PLUMBING
- PAINT
- FINISH
- IRON
- STEEL
- GLASS
- ALUMINUM
- COPPER
- BRASS
- LEAD
- ASBESTOS
- PCB
- CONTAMINATED SOIL
- CONTAMINATED WATER
- ASBESTOS
- LEAD
- PCB
- OTHER

MESA ELECTRONICS INC.  
700 N. LAUREL  
LOMBARD, IL 60148

**FORM**  
Project Name  
700 N. LAUREL  
LOMBARD, IL 60148

PROJECT CONSULTANTS

101 PLAN

89A

COVER

PROJECT NO. AE-001  
DATE: 10/1/10  
SCALE: AS SHOWN

NO. OF SHEETS	24
SHEET NO.	AD-101
DATE	1/1/00
BY	AD-101
CHECKED BY	
DATE	
APPROVED BY	
DATE	
DESIGNED BY	
DATE	
DRAWN BY	
DATE	

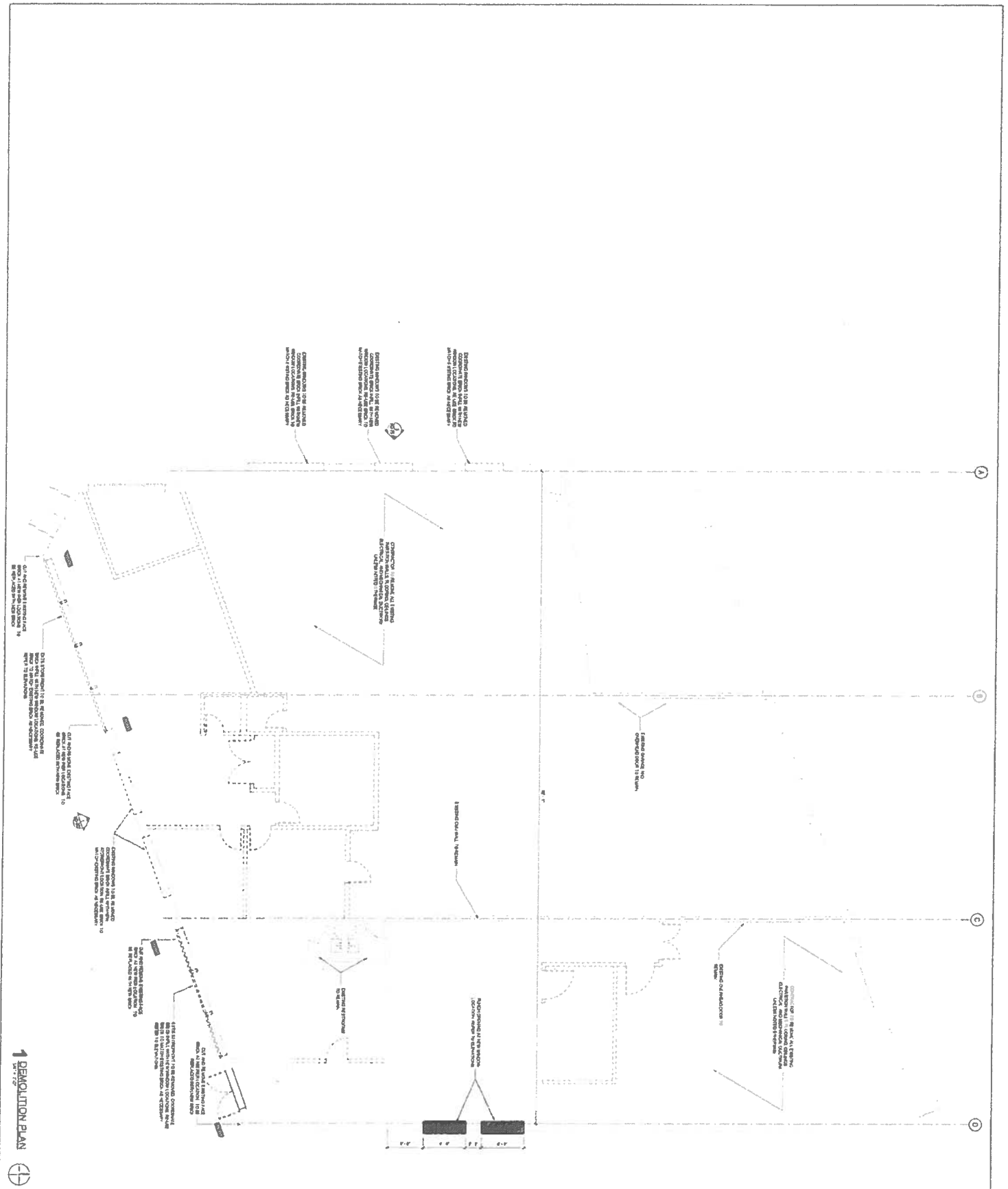

↑ REVOLUTION PLAN



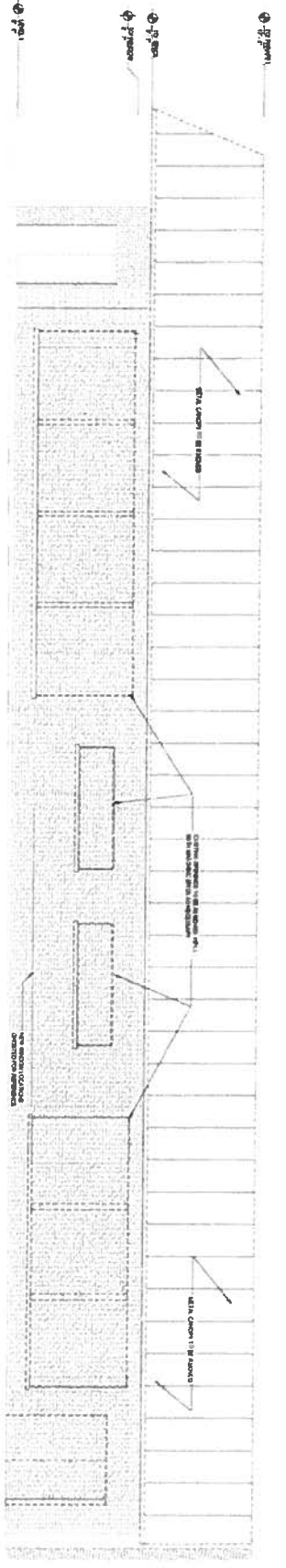

1 SOUTH ELEVATION DEMO

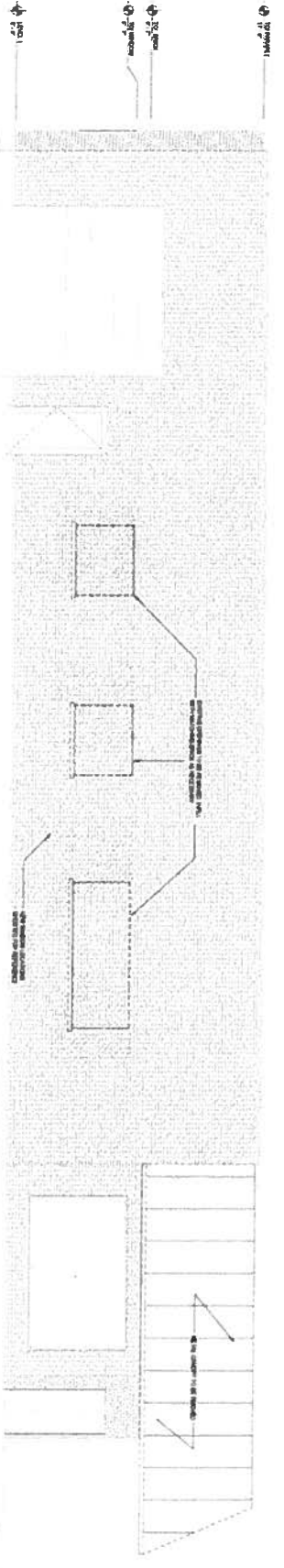

2 WEST ELEVATION DEMO

MESA ELECTRONICS INC  
**EYE MESA**  
 A DIVISION OF  
 MESA ELECTRONICS INC

**IPORM**  
 Industrial Process  
 Operating Manual  
 Version 1.0  
 Project: 10000

PROJECT CONSULTANTS

KEY PLAN

SCALE

DATE: 10/10/00  
 DRAWN BY: J. J. JENSEN  
 CHECKED BY: J. J. JENSEN  
 PROJECT: 10000  
 DRAWING: DEMO-ELEVATIONS

AD-201

Room Schedule	Area	Occupancy
101 OFFICE 01	296 SF	
102 BATH 1	18 SF	
103 OFFICE 02	137 SF	
104 OFFICE 03	137 SF	
105 OFFICE 04	137 SF	
201 LOBBY/ENTRANCE	213 SF	
202 RECEPTION	229 SF	
203 WORKFLOOR	770 SF	
204 IT CLOSET	32 SF	
205 LOADING	847 SF	
301 M.V.	566 SF	
302 CONF.	421 SF	
303 OFFICE	1115 SF	
304 MOCK	63 SF	
305 KITCHEN	78 SF	
306 UTILITY	32 SF	
307 BATH 2	33 SF	
308 BATH 3	41 SF	
309 BATH 4	28 SF	
310 W.O.	313 SF	
311 SERVICE CORRIDOR	597 SF	
401 LORIS	500 SF	
402 LORIS WEST	62 SF	
403 BATH 5	27 SF	
404 TECH	694 SF	
405 WAREHOUSE	1271 SF	
500 CORRIDOR	702 SF	
	8137 SF	

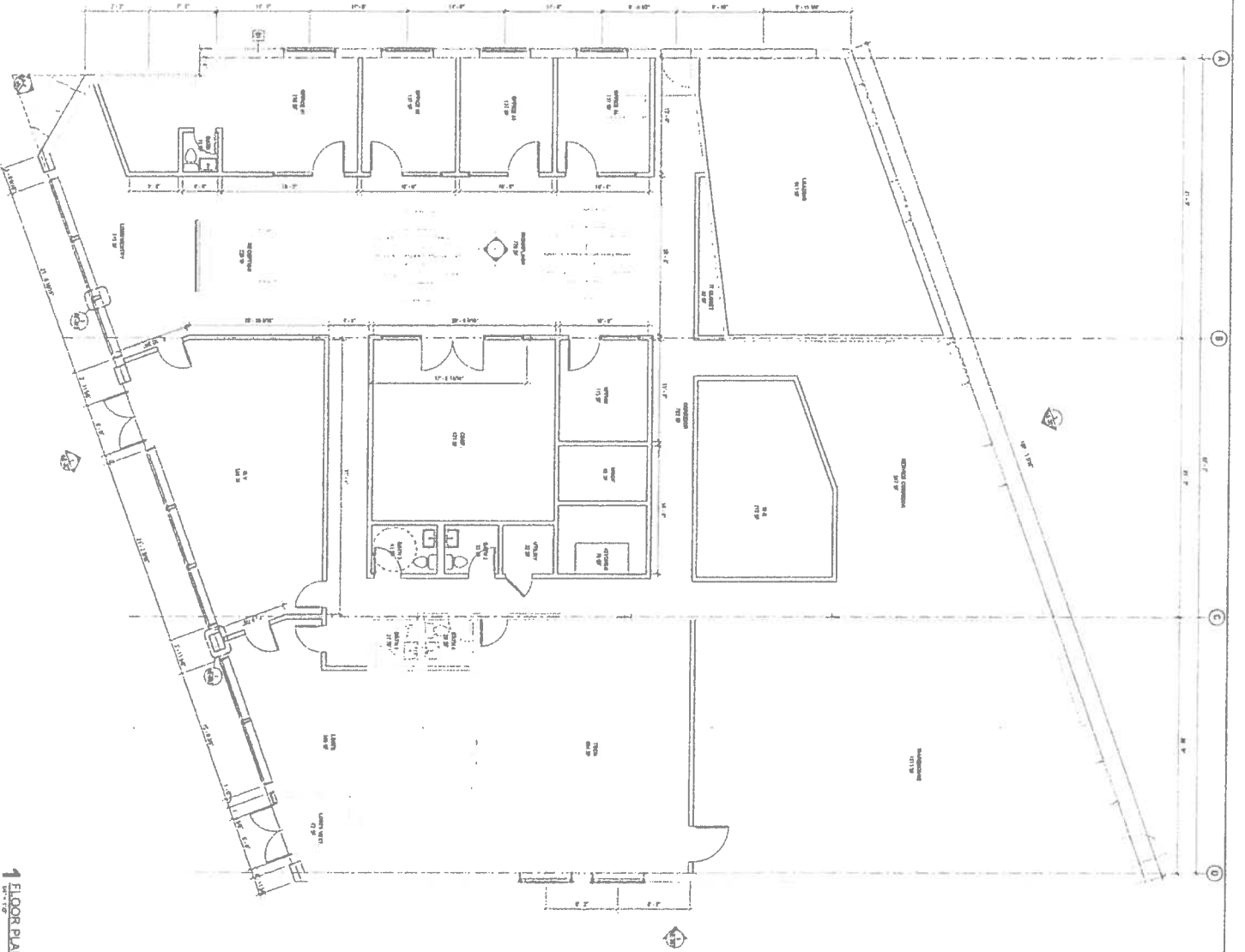

1 FLOOR PLAN



<p><b>MESA ELECTRONICS, INC.</b>  <b>IRDM</b>          1700 N. 14th Street          Phoenix, AZ 85016</p> <p>PROJECT CONSULTANTS</p>	<p>REV PLAN</p> <p>SEAL</p>	<p>DATE: 10/11/11</p> <p>SCALE: AS SHOWN</p> <p>PROJECT NO: AE-101</p>
--	-----------------------------	--

φ 1000  
φ 1000  
φ 1000  
φ 1000

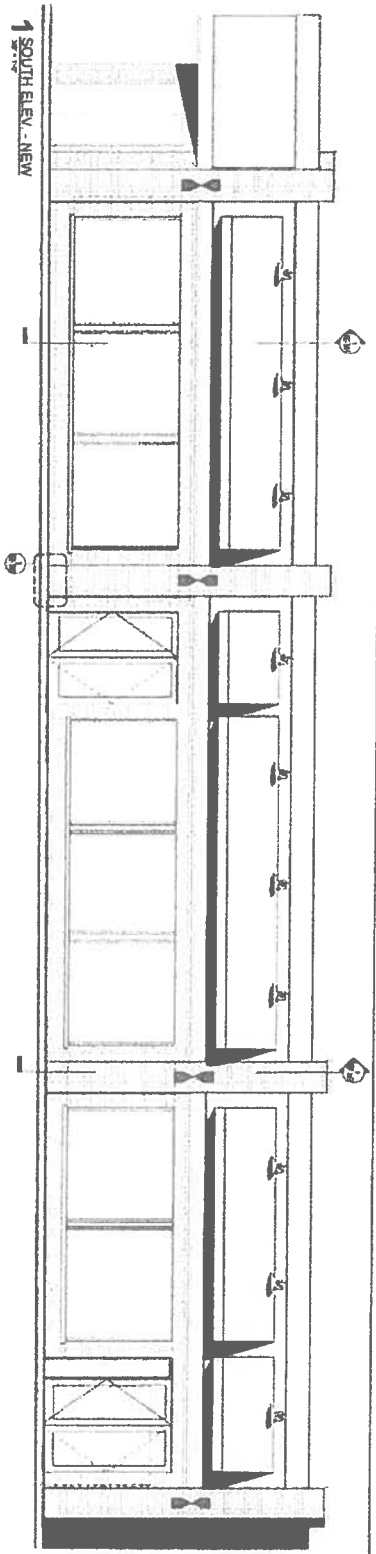

φ 1000  
φ 1000

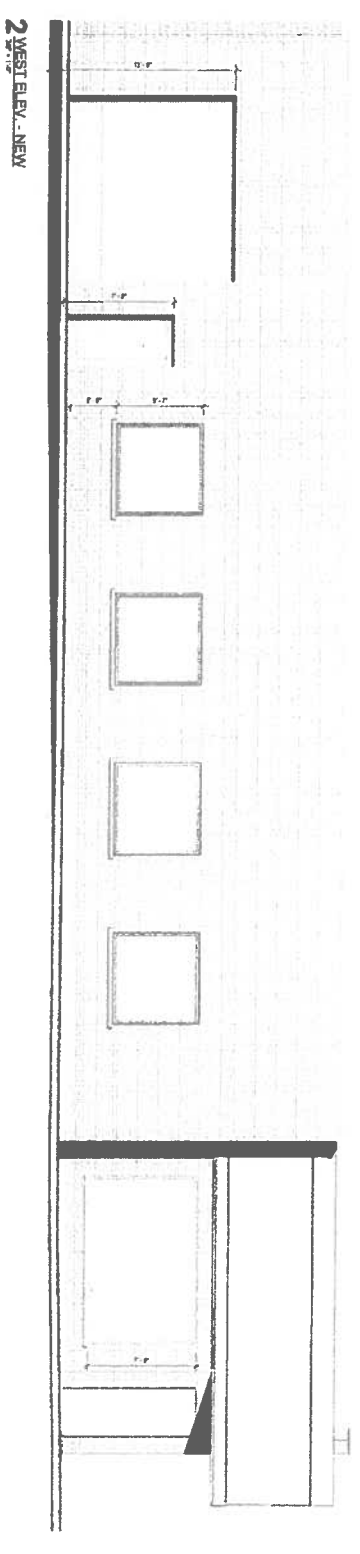

φ 1000  
φ 1000

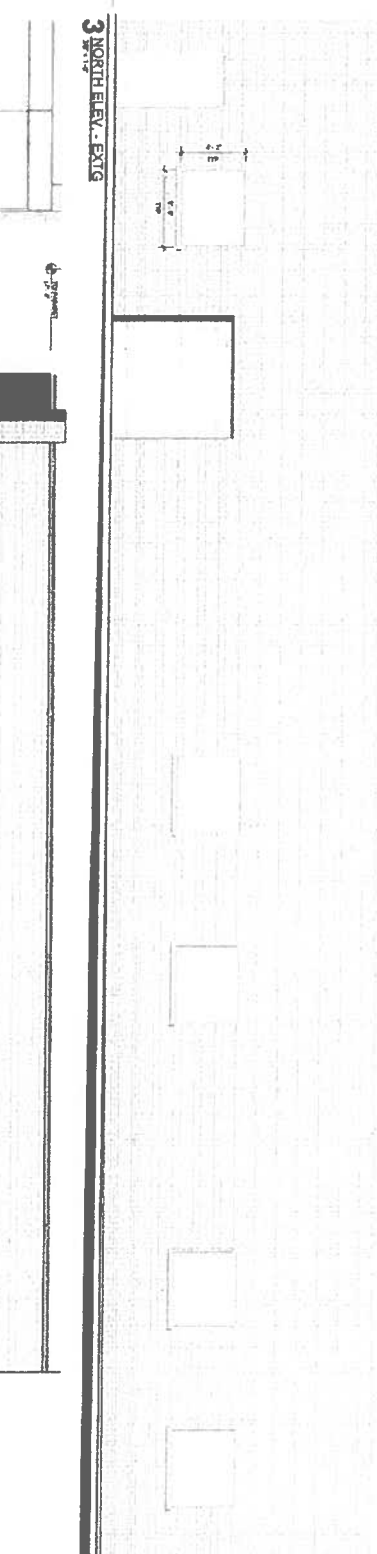

φ 1000  
φ 1000

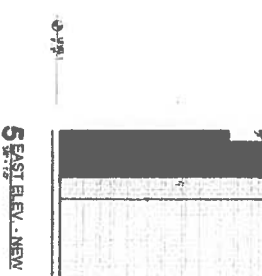
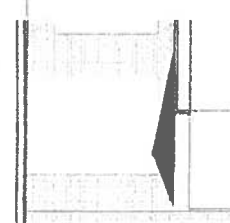

MESA ELECTRONICS INC  
**EYE MESA**  
ELECTRONICS, INC.

**IFORM**

Head Office  
17000 N. 31st St  
Phoenix, AZ 85018

PROJECT CONSULTING

REV PLAN

SCALE

NO.	REVISIONS	DATE	BY

DATE PLOTTED: 14-01-12  
DRAWING NO: **AE-201**  
SCALE: 1/8"=1'-0"

NO.	REVISION
1	ISSUE FOR PERMITTING
2	ISSUE FOR CONSTRUCTION
3	ISSUE FOR AS-BUILT
4	ISSUE FOR ARCHIVE
5	ISSUE FOR FINAL REVIEW
6	ISSUE FOR FINAL APPROVAL
7	ISSUE FOR FINAL RECORD
8	ISSUE FOR FINAL ARCHIVE

PROJECT NO. **AE-301**

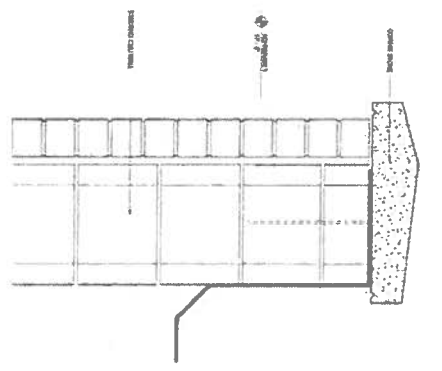

**4** Detail of Section 5

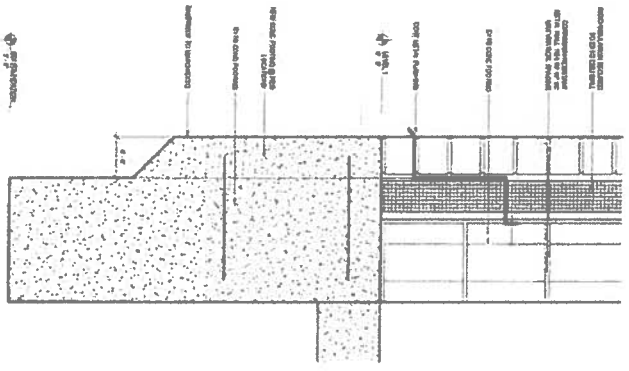

**8** Detail of Pier

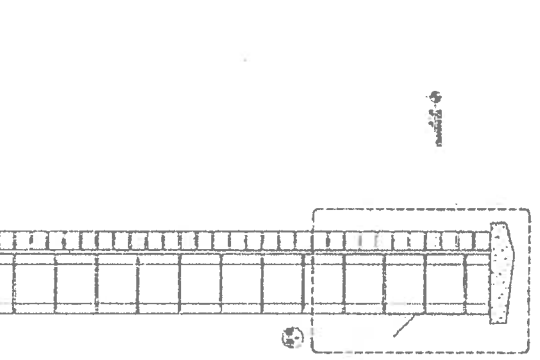

**7** WALL SECTION at PIER

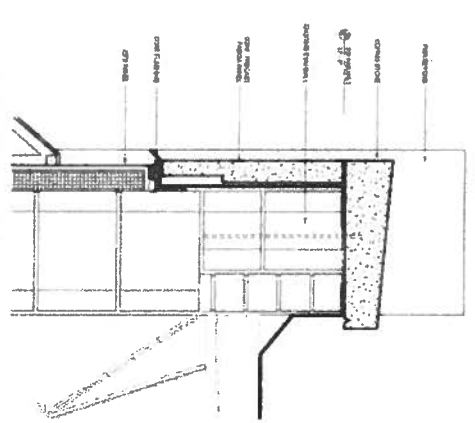

**2** SECTION DETAIL AT PARAPET

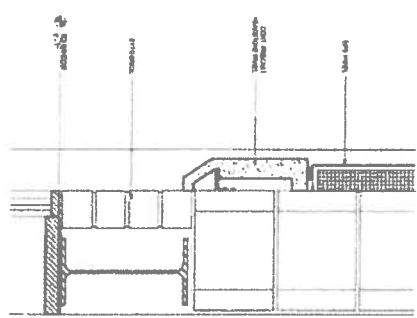

**3** SECTION DETAIL AT WINDOW HEAD

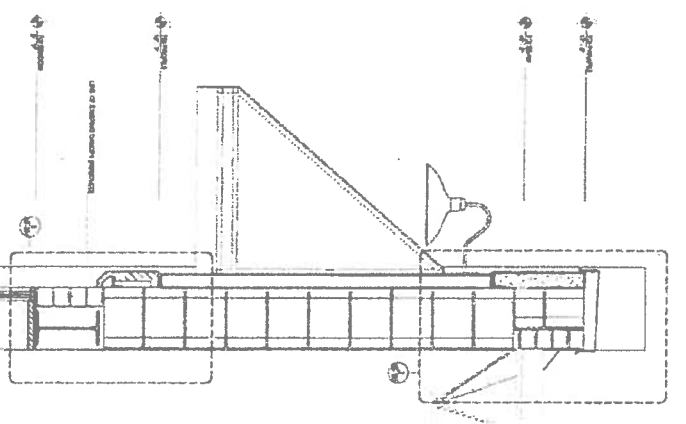

**1** WALL SECTION



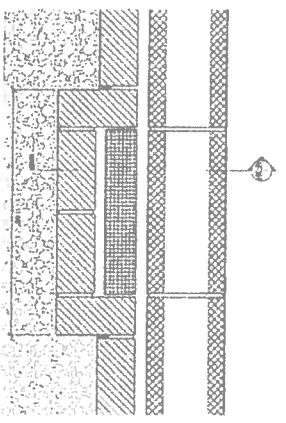

1 PLAN DETAIL AT PIER

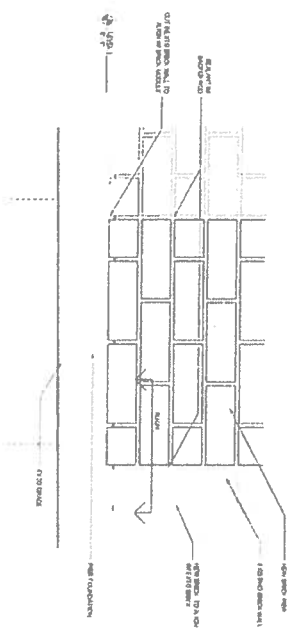

2 ENLARGED ELEVATION AT PIER

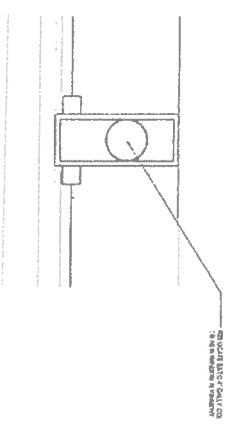

3 COLUMN DETAIL

NO.	DESCRIPTION	SECTION AND DETAILS
1	PIER HEAD	1
2	PIER BODY	2
3	PIER FOOTING	3

**QUOTATION  
THATCHER OAKS INC  
AWNINGS AND SIGNS**

718 Industrial Drive  
Elmhurst, IL 60126  
(630) 833-5700 Fax (630) 833-5795

CHICAGOLAND'S FULL SERVICE AWNING & SIGNS COM  
COMMERCIAL-INDUSTRIAL  
CUSTOM DESIGNED FABRIC AWNINGS & SIGNS  
COMMERCIAL CLEANING AND MAINTENANCE

**TO:** Mesa Electronics Inc.  
130 E. St. Charles Road  
LOMBARD, IL  
60148

Date: 07/09/2014

Quote #: 24782

Delivery:

Terms 1/2 Deposit Balance on Completion

DESCRIPTION	AMOUNT
<p>Proposal is to manufacture and install three (3) traditional style awnings for Mesa Electronics Inc. 130 E. St. Charles Rd., Lombard, IL 60148. The location of the awnings is on the south elevation. The sizes are 22'-0" wide, by 3'-0" high, by 3'-0" projection.</p> <p>All frames to be made of galvanized steel or aluminum and will be completely welded. All welds will be ground smooth and primed silver. All frames are covered by our LIFETIME TigerFrame Warranty.</p> <p>Fabric to be #4608 Black Sunbrella 100% Solution Dyed Acrylic. This material carries a ten (10) year warranty.</p> <p>Graphics to include descriptors and will be applied using the Sunbrella Graphics system. This system utilizes heat and pressure to apply high quality 3M vinyl to the fabric.</p> <p>Price includes taxes and installation. Any permit requirement will include an additional fee.</p> <p>Thank You for your interest in Thatcher Oaks Awning Company. Kevin Eltoft (630) 452-1720</p>	
<p align="right"><b>Total Cost for Items on Quotation.....</b></p>	<p align="center"><b>\$7,320.00</b></p>

It is the intent of the Seller to deliver to Buyer the products so stated in this contract, within the time frame so stated, subject to our ability to produce materials, and is subject to labor disputes, acts of God, and other delays beyond our control.

**CUSTOMER DEPOSIT IS NON REFUNDABLE 5 DAYS AFTER ACCEPTANCE OF CONTRACT.**

For the purpose of securing payment and performance of the obligation hereunder, Seller shall have, and Buyer hereby grants to Seller, a purchase money security interest in said property. The property and all of the apparatus, appliances, supplies, accessories and parts remain the property and security of Seller for said indebtedness until this contract is paid in full. In the event Seller has to remove property due to nonpayment, any monies paid on account shall remain the property of Seller as liquidated damages, and any reinstallation shall be subject to renegotiation. All new installations are guaranteed against defect in material or workmanship for three years after installation.

ACCEPTED \_\_\_\_\_ DATED \_\_\_\_\_ BY \_\_\_\_\_  
BUYER SELLER

DEPOSIT \_\_\_\_\_ We May Withdraw this proposal if not accepted within \_\_\_\_\_ days.



# B.H. AWNING & TENT

2275 M-139, Benton Harbor, MI. 49022  
 Ph: 800-272-2187 Fax: 888-272-2197 E-mail: dave@bhawning.com

# Proposal

Date	Proposal #
8/28/2014	P1519R

Proposal Submitted To:	
Mesa Electronics, Inc 41 S. 2nd Street St. Charles, IL 60174	
Customer Contact	Henry Mesa
Phone:	630-880-9443
E-mail:	henrymesaemail@gmail.com

Ship To:
Mesa Electronics, Inc. 130 E St. Charles Road Lombard, IL

Total # of Pages	Delivery Date	Sales Rep
1	4-6 weeks	DM

Qty	Description	Total
	Per Information Provided by Owner.	8,052.00
	Design, Fabricate and Install (3) Shed Style Awnings with 8" rigid valance and closed ends.	
	Frames shall be 1" square extruded aluminum tubular framing with all joints welded and ground smooth. Mill Finish.	
	Fabric attachment by "staple-in" method from Steel Stitch Corp.	
	Fabric: #4608 Sunbrella Black. (Meets ASTM E84 Class B Flame Spread Index)	
	Dimensions: 1 @ 256" wide x 46" high x 33 1/2" projection 1 @ 362" wide x 46" high x 33 1/2" projection 1 @ 283" wide x 46" high x 33 1/2" projection	
	Graphics on Sheds White (max. size 30" high x 150" wide) Add	\$2000.00
	City Permit if Required Add	\$200.00
	Non Union Installation	
	Must be field verified and prints approved before production.	
	Illinois Sales Tax	138.00
	<b>Awning Permit included with General Contractor's Permit</b>	<b>Total</b>
		<b>\$8,190.00</b>

**PRICE DOES NOT INCLUDE: ADDITIONAL BACKING, ENGINEERING, LICENSES, BONDS, PERMITS OR ELECTRICAL**

**TERMS**

Service charge of 1 1/2% per month will be added on any past due balance. It is understood and agreed that the title of the said property shall remain the property of B.H. Awning & Tent Co., Inc. until the whole amount of the purchase has been paid.

All material is guaranteed to be as specified. All work to be completed in a workman like manner according to standard practices. Any alteration or deviation from above specifications involving extra costs will be executed only upon written orders, and will become an extra charge over and above the estimate. All agreements contingent upon strikes, accidents, or delays beyond our control. Owner to carry fire, tornado, and other necessary insurance. Our workers are fully covered by Workman's Compensation Insurance. NOTE: This proposal may be withdrawn by us if not accepted by 9/26/2014.

Authorized Signature:  David Murphy - Operations Manager

**ACCEPTANCE OF PROPOSAL** - The above prices, specifications and conditions are satisfactory and are hereby accepted. You are authorized to do the work as Specified.

Signature: \_\_\_\_\_ Date: \_\_\_\_\_

Print Name & Title: \_\_\_\_\_



# Chesterfield Awning Co.

16999 Van Dam Road South Holland, IL 60473 Website: [www.chesterfieldawning.com](http://www.chesterfieldawning.com)  
Phone (708) 596-4434 Fax: (708) 596-9469

**Install at: Mesa Electronics**  
130 E. St. Charles Rd. Lombard, IL 60148  
**Billing address: Same**  
Contact Person: Henry Mesa  
Phone: 630-880-9443  
Email: [hmesa@mesaelectronics.com](mailto:hmesa@mesaelectronics.com)

## REVISED CONTRACT / ESTIMATE

August 27, 2014

### Three (3) custom canvas awnings made and installed

Style: Straight  
Size(s): 2 at 22'-0" wide x 2'-0" projection x 4'-0" drop  
Material: Sunbrella #4608 – Black  
Frame: Welded- using aluminum square tubing  
8" double front bar (Removable so graphics can be changed without replacing entire awning fabric)  
**Graphics: Includes \$450.00 allowance for graphics**  
Painted on – White (Any font style)

**\*Includes \$300.00 allowance for permits**

\*Bid based on estimated sizes (Drawing does not match proposed sizes on site)

**Does Include: Standard Chesterfield labor + Insurance**

**Does not include: Lights, electric, bottom covers, special shop drawings or any permits**

Total Price..... **\$7834.00**  
Down Payment ... \_\_\_\_\_  
Balance due ..... \_\_\_\_\_

**Installation: Approx. 8 weeks upon down payment**

*Installation time subject to change depending on Delayed Graphics Approvals or Outsourced Graphics*

**Terms: 50% down, balance upon installation**

Customer \_\_\_\_\_ Date: \_\_\_\_\_ Sales: Ed Ritzema

After the company goes into production on this merchandise, this contract cannot be canceled and the purchaser is responsible for the whole amount contracted herein. The merchandise is the property of the Chesterfield Awning Company, Inc. until the whole amount of the contract is paid in full. A service charge of 1 ½ percent monthly will be added to any unpaid balance after 30 days from installation. This is an effective annual rate of 18 percent.

CHECKVELOCITY: If your check is returned for non-sufficient funds, you expressly authorize your account to be electronically debited or bank drafted for the amount of the check plus any applicable fees. The use of a check for payment is your acknowledgement and acceptance of this policy and its terms and conditions. [www.checkvelocity.com](http://www.checkvelocity.com) 800-430-2370



# ALTERNATING currents corporation

21w180 Hill Avenue, Unit 2A/C Glen Ellyn, Illinois 60137  
 P: 630-545-9343 ■ F: 630-545-9392 ■ W: www.altcur.com



## Estimate

Date	Estimate #
8/20/2014	28579

Name / Address

**MESA Electronics Inc.**  
 attn: Andrew Howell  
 411 South 2nd Street  
 St. Charles, Illinois 60174

Pricing Valid	Project
30 days	Install outside light...

Line	Description
	Project: Install outside light fixtures 8/20/14 Location: 130 East St. Charles Road, Lombard, Illinois
1	Install 14 electrical openings for outside light fixtures with brick siding at 10 to 15-feet high
2	Install 14 light fixtures (light fixtures provided by customer) at 10 to 15-feet high
3	Install 1, 24-hour timer for lights
4	Install 1, 20-amp breaker
	Note: Drywall will be damaged to complete this project. Alternating Currents will not be held responsible to repair or replace the damaged drywall. It is the responsibility of the customer.

Note: Damage to drywall/plaster may occur to complete this work. Alternating Currents shall not be responsible for repair or replace damage drywall/plaster. It is the responsibility of the customer.

Note: A building permit may be required for this project. It is the responsibility of the customer to obtain a permit unless noted above.

Note: Standard white receptacles, switches, and rotary dimmer switches with white plastic cover plates will be installed unless noted above. Toggle with slide dimmer switches: \$30 each.

Note: ComEd charges are not included in this estimate. The charges are the responsibility of the customer.

Note: Telephone and cable connections do not include hook up to incoming lines.

Note: Any electronic equipment and machines will need to be unplugged during installation of the above electrical items. All furniture and personal belongings in work area need to be removed from area prior to installation. We shall not be held responsible for any damaged items.

If accepted, customer will pay 50% of estimated price at time of acceptance as down payment, and the balance due upon completion of the work.

Any changes made by customer from customer's original plan will be charged at an add'l. cost of labor hours plus materials. All change orders will be signed and paid in full before work is started. If customer cancels contract prior to completion of the work, customer will pay for services and materials incurred by Alternating Currents before ending contract. All material is guaranteed to be as specified, and is subject to a price change after valid date due to market conditions. Work shall be completed in a workmanship manner according to standard practices. All workers are fully covered by Workers' Compensation Insurance. It is agreed that all material shall remain the property of Alternating Currents Corporation until payment in full has been made. We accept cash, check, MasterCard, Visa, Discover.

In addition, in the event that the customer fails to make timely payments of any invoice, said customer shall be liable for reasonable costs incurred in collection of any sum due and owed to Alternating Currents, including but not limited to attorney fees, court costs, and expert witness fees incurred.

This estimate assumes the electrical wiring in this building is in compliance with the National Electrical Code and is operating correctly. If Alternating Currents finds incorrect wiring in the building through installation of the above items with no fault of its own, an estimate will be provided and the repairs will be treated as a change order. Illinois Attorney General's Consumer Rights pamphlet available at our web site:

<http://www.altcur.com/documents/homerep0403.pdf> \*Actual item counts will be reflected on final invoice after trim, listing credits and debits.

This contract is agreed upon by the following parties if signatures of both parties are listed below.

**Total \$2,973.00**

-----  
 Alternating Currents' signature and date

-----  
 Customer's signature and date

Thank you for the opportunity to provide this estimate!  
 Please contact us with any questions.



Licensed - Bonded - Insured

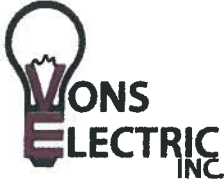

**Vons Electric, Inc.**  
 2701 Dukane Drive  
 St. Charles, Illinois  
 60174-3343  
 Ph: 630.377.VONS (8667)  
 Fx: 630.377.7975

# Proposal

Date	Estimate #
8/26/2014	2690

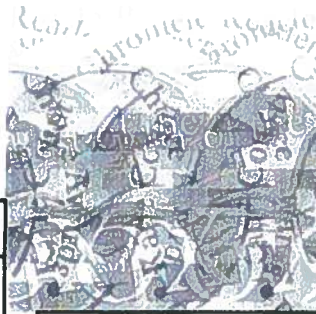

Client
Mesa Electronics 130 E. St.Charles St. Lombard IL 60148

Project
14-0180E

Description of Work	Qty	Cost	Total
Provide and Install for exterior light upgrade 14-light fixture openings (fixtures by others) 1-timer located by the existing electric panels Run a conduit from the timer to the south wall, pipe light fixture openings exposed along the wall Return after exterior is complete to hang light fixtures NOTE: Please allow us to hang fixture above canopy before canopy is installed  Excludes: city permit fees painting of conduits purchase of light fixtures		4,175.00	4,175.00
Thank you for the opportunity to do business!		<b>Total</b>	\$4,175.00

Vons Electric, Inc. ("Contractor") hereby proposes to perform the aforementioned Work at the Project Address referenced above for the price referenced above. Contractor agrees to perform the work set forth above in a workmanlike manner. By signing this document, Client hereby retains Contractor to perform said Work and agrees to pay Contractor the sum set forth above immediately upon completion of the work. If a deposit is referenced above, the deposit shall be due upon execution of this agreement. Payment that is not made on a timely basis shall bear interest at the rate of twelve percent (12%) per annum. In addition, Client agrees to pay any attorney's fees and court costs incurred by Contractor in enforcing the terms of this agreement. This agreement is executed in Kane County, Illinois, and shall be construed in accordance with the laws of the State of Illinois.

Client Signature: \_\_\_\_\_

Date of Acceptance: \_\_\_\_\_



**WWW.VONSELECTRIC.COM**  
**LICENSED, INSURED & BONDED**



**Certified  
 Installer**

.....

909 S. Stewart Ave.  
Lombard, IL 60148  
630-627-5852

**Les Electric, Inc.**

**Proposal**

September 3,

2014

Job Location:

Mesa Electronics, Inc.  
Attn: Andrew Howell  
130 E. St. Charles  
Lombard, IL  
Phone: 630-715-7894  
E-mail: [ahowell@mesaelectronics.com](mailto:ahowell@mesaelectronics.com)



Les electric will do following electrical work such as:  
-dedicated circuit line from the circuit breaker box to the front of the building controlled by timer(10 light fixtures +4 light fixtures)according to drawings.

**Cost of the labor will be \$1,150.00 not included cost of fixtures.**

Les Electric will supply all standard materials.  
All work will be performed to meet satisfaction of city codes and standards. Les Electric is licensed, bounded, insured and register at the Village of Lombard

Acceptance of Proposal

Signature



.....



Expiration Date: 09/27/14

### Quotation

**TO:**  
**CASH SALES - ST CHARLES**  
**ST CHARLES CASH**  
**ST CHARLES, IL 60174-3439**

**Project Info:**  
**Project: MESA ELECTRONICS**  
**Job #: #LI-082814-43128**  
**Bid Date: 08/28/14**  
**Bid Time: 02:00 PM**  
**Quoter: HELSPER, SANDY**

Type	Quantity	Vendor	Description	Unit or Lot#	Unit Price	Ext Price
<b>RAB</b>	10	RAB LIGH	GN1LED13NSACB (BLACK)	Unit	284.286/EA	2,842.86
<b>PROGRESS</b>	4	Stock	PROG P5675-20 2-75w PAR-30/BR- Notes: UL Listed for indoor use as shown. For UL Wet Location use, accessory lens, P8799-31, is required - order separately -	Unit	100.890/ea	403.56
	8	Stock	PHIL 50PAR30L/IRC/FL25-120V 15PK REPLACEMENT FOR 75PAR 30 THAT IS DISCONTINUED Per item quantity: 2	Unit	14.950/ea	119.60
--- Subtotal ---					130.79	523.16

\*\*\* If Attic Stock is required, please provide information. No Attic Stock will be included unless advised \*\*\*

\*\*\*\* TAX NOT INCLUDED IN TOTAL \*\*\*\*

Pricing is based on the quantities provided. Please verify that counts on Fixtures,Lamps and Accessories meet your required totals. Any variance may require re-quote.  
 Expedited shipments may incur freight charges.  
 Any delivery address changes may incur re-consignment fees as determined by the carrier.  
 All lamps subject to stock availability at time of order.

PLUS FREIGHT PROGRESS LIGHTING

**From:**  
**STEINER ELECTRIC-ST.CHARLES**  
**PHONE 630-377-6600**  
**3755 SWENSON AVE**  
**ST CHARLES, IL 60174-3439**  
**Printed By: HELSPER, SANDY**  
**Sandy Helsper**  
**shelsper@stnr.com**  
**Ph: 630-513-2316**  
**Fax: 630-513-2390**

<b>Total</b>	<b>3,366.02</b>
--------------	-----------------

**Notes**

Manufacturer freight terms apply and may be subject to fuel or material surcharges, as determined by the Manufacturer. Subject to Steiner current terms & conditions, a copy is available on our website at [www.steinerelectric.com](http://www.steinerelectric.com).



**Quotation**

QUOTE DATE	QUOTE NUMBER
08/28/14	S003484284
PAGE NO	
1 of 1	

**BROOK ELECTRICAL SUPPLY**  
 880 S ROHLWING RD  
 ADDISON, IL 60101-4218  
 847-353-6300 Fax 847-353-6301

erivera@brookelectrical.com

QUOTE TO:  
 BROOK CASH CUSTOMER - ADDISON  
 880 S ROHLWING RD  
 ADDISON, IL 60101-4218

SHIP TO:  
 BROOK CASH CUSTOMER - ADDISON  
 880 S ROHLWING RD  
 MESA ELECTRONICS  
 ADDISON, IL 60101-4218

CUSTOMER NUMBER	CUSTOMER ORDER NUMBER	JOB NAME	QUOTED TO	
53414	MESA ELEC	LIGH QUOTE	E OLSON	
SALES PERSON	SUPPLY	FREIGHT ALLOWED	EXPIRATION DATE	
EDDIE RIVERA	BOT OUR TRUCK	No	10/12/14	
ORDER QTY	PN#	DESCRIPTION	UNIT PRICE	EXT PRICE
4ea	78524756752	PROG P5675-20 2-75W PAR-30/BR-30 WA	81.990 e	327.96
10ea	01981302956	RAB GN1LED13NSACB GOOSENECK STYLE1 13W NEUTRAL LED ANG CONE SHADE SPOT REFL	235.000 e	2350.00

**TERMS & CONDITIONS**

This order is subject to Company Terms and Conditions of Sale, which provisions shall govern in the event of any conflict with any Terms or Conditions of Purchaser's proposal, purchase order or other documents. All quotes/bids for Pipe and Wire are good for the date of the bid only. No extension of the pricing of these items is authorized by any employee of the Company without express written consent in the form of an official letter or signed acknowledgement of an Officer of the Company.

<b>Subtotal</b>	<b>2677.96</b>
<b>S&amp;H CHGS</b>	<b>0.00</b>
<b>Sales Tax</b>	<b>220.93</b>
<b>Amount Due</b>	<b>2898.89</b>

**Ganser, Jennifer**

---

**From:** Emma Olson <eolson@mesaelectronics.com>  
**Sent:** Thursday, August 28, 2014 3:34 PM  
**To:** Ganser, Jennifer  
**Subject:** Lights Quotes  
**Attachments:** Steiner Quote.pdf; Brook Electric.pdf

Hello again!

I hope you're not sick of me yet, because I have at least one more email to send to you besides this one! Anyway, here are the quotes for the lights for the exterior. One was sent to me in the body of an email (see below) though the other two were written as your typical quote. I was wondering.....I could go to home depot and buy these lights rather than going through a vendor. Is there a way for me to show that as an option? One place told me they couldn't give me an 'official' quote because I could just use the information off their website. Is that allowed....?

**From:** Sunshine Lighting <[sunshinelights@aol.com](mailto:sunshinelights@aol.com)>  
**Subject:** Quote  
**Date:** August 28, 2014 at 11:06:14 AM CDT  
**To:** "[eolson@mesaelectronics.com](mailto:eolson@mesaelectronics.com)" <[eolson@mesaelectronics.com](mailto:eolson@mesaelectronics.com)>

Quantity 4/ Progress P5675-20 @ \$105.05ea. \$420.20

Sunshine Lighting  
2312 W. Main Street  
St. Charles, IL 60175

Sent from my iPad

## Ganser, Jennifer

---

**From:** Emma Olson <eolson@mesaelectronics.com>  
**Sent:** Friday, August 29, 2014 9:34 AM  
**To:** Ganser, Jennifer  
**Subject:** Fwd: quote Rab

And I just got the final quote for the lights! There are now three quotes for 10 RAB Gooseneck lights and three quotes for 4 Progress Sconce lights.

Emma Olson  
[eolson@mesaelectronics.com](mailto:eolson@mesaelectronics.com)  
630.443.6683

Begin forwarded message:

**From:** "jim conway" <[jjmc@westsidedelivers.com](mailto:jjmc@westsidedelivers.com)>  
**Subject:** quote Rab  
**Date:** August 29, 2014 at 9:32:14 AM CDT  
**To:** <[eolson@mesaelectronics.com](mailto:eolson@mesaelectronics.com)>

Thanks for your request.

Per your request.

(10) GN1LED13NSACB                   \$248.75/EA  
5 FACTORY STOCK  
BALANCE 3-4 WEEKS

Thanks,

Jim Conway  
West Side Electric Supply  
1530 N. LaFox  
South Elgin, IL 60177  
847-737-7003 Direct  
847-468-1000 Main Line



<https://westsidedelivers.com>

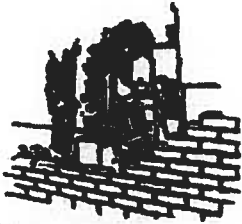

# Soumar Masonry Restoration, Inc.

"Serving Chicago, its suburbs, and the midwestern states for 60 years"

1033 S. Rt. 83 (Frontage Rd.)  
Elmhurst, IL 60126-4966  
Masonryres@aol.com

"See us at" www.soumar.com

1-800-737-8672  
630-834-3400  
Fax 630-834-3401

Mesa Electronics  
130-134 E. St. Charles Rd  
Lombard, Ill 60148

CONTRACT

August 28, 2014

Address and area where work will be performed: 436 N. Adams Hinsdale, Ill

All work as per specifications received called Mesa Electronics, Inc. Exterior Renovation Project # 0000. All demo of the existing canopy and glass windows is by others. This contractors scope of work is for masonry alterations and includes, the south facing side for alterations, constructing of four pillars, installation of the necessary steel window lintels and installation of the coping stone and stone fascia for the top parapet walls on the window heads on the south and front portion of parapet wall only on the west elevation. Also alteration of the west facing side for creation of four new window openings. All windows and door install is by others. All drywall and interior work is by others. A pre-construction meeting will be needed before job is started. Brick samples will be shown to the owner for approval. Some stime will be needed for order of the brick and order of the stone coping and stone window head fascia. All permits is by others. Limestone may be used in lieu of eh pre-cast concrete if owner approved. Areas are boarded up after each day. Any other type of overnight security is by others. Also any dust partitions or protection of the interior is by others. Quote includes the cost of the steel lintel beams. All debris related to the masonry work only is removed and hauled away daily in our own dumpsters.

### Work Specifications:

- Carefully remove with hand tools at locations indicated all the required masonry. Use all shoring as needed for the work. Cut out full units from joint to joint and in a manner to permit replacement with full size units. Support and protect masonry indicated to remain which surrounds removal area. Chisel, saw cut and or rake out all deteriorated or loose mortar as needed on all areas worked.
- Install new and/or salvaged masonry units as required. Install the necessary steel lintels and proper flashing as required Fit replacement units into bonding, joint size and coursing pattern of existing brick. If cutting is required, use motor-driven saw designed to cut masonry with clean, sharp unchipped edges. Galvanized metal ties and wire reinforcement are installed if needed or required.
- A masonry Type N Brizment cement is mixed and applied according to manufacturer's requirements. No admixtures except coloring are used unless requested or required by owner. All areas are washed with a non acidic masonry detergent as needed after completion.
- There is a three year guarantee on all of our work performed from the day of completion. Price includes labor, material and insurance. We will make every reasonable effort to match materials, but cannot gurantee a perfect match. All debris from our work is removed and hauled away by our company.

### Terms and payments:

South elevation masonry alterations	\$29,500.00
West elevation alterations	13,600.00
Stone coping and window head fascia	24,800.00
<b>Total</b>	<b>67,900.00</b>

Work to be scheduled after a signed copy of this quotation is returned to our office. Progress payments are to be agreed upon and put in writing by both this contractor and the customer or acting agent before project is started.. If the account is collected through legal actions you will be responsible for any lien, expeditor, arbitration, finance and or attorney fees and all related court costs for the unpaid balance due. We carry workers compensation, liability and vehicle insurance. Any handwritten changes or adjustments to this contract have to be agreed upon and initialed by the contractor and the buyer or acting agent of this contract. This contract and any related documents, drawings or confidential information provided by Soumar Masonry Restoration, Inc. is intended for the sole use to obtain your business. Any use, distribution or copying of enclosed contract documents to others for the intended use of competitive bidding is prohibited and will be strictly enforced. Please sign both copies. White copy to contractor and yellow copy to buyer Please call any time if you have any questions. This contract is subject to change unless acceptance is made within 30 days of the date of this contract.

Contract submitted by: 	Title: President	Date: Aug 28 2014
Contract accepted by:	Title:	Date accepted:





# CERTIFICATE OF LIABILITY INSURANCE

DATE (MM/DD/YYYY)  
12/13/2013

THIS CERTIFICATE IS ISSUED AS A MATTER OF INFORMATION ONLY AND CONFERS NO RIGHTS UPON THE CERTIFICATE HOLDER. THIS CERTIFICATE DOES NOT AFFIRMATIVELY OR NEGATIVELY AMEND, EXTEND OR ALTER THE COVERAGE AFFORDED BY THE POLICIES BELOW. THIS CERTIFICATE OF INSURANCE DOES NOT CONSTITUTE A CONTRACT BETWEEN THE ISSUING INSURER(S), AUTHORIZED REPRESENTATIVE OR PRODUCER, AND THE CERTIFICATE HOLDER.

**IMPORTANT:** If the certificate holder is an ADDITIONAL INSURED, the policy(ies) must be endorsed. If SUBROGATION IS WAIVED, subject to the terms and conditions of the policy, certain policies may require an endorsement. A statement on this certificate does not confer rights to the certificate holder in lieu of such endorsement(s).

<b>PRODUCER</b> Hicks Insurance Group 19144 S 88th Ave Mokena IL 60448	<b>CONTACT NAME:</b> Susan Devries <b>PHONE (AC No. Ext.):</b> (708) 532-7474 <b>FAX (AC No.):</b> (708) 532-7677 <b>E-MAIL ADDRESS:</b> susan@hicksinsurance.com
<b>INSURED</b> SOMAR MASONRY RESTORATION INC 1033 S STATE ROUTE 63 ELMHURST IL 60126-4966	<b>INSURER(S) AFFORDING COVERAGE</b> INSURER A: Erie Insurance Exchange 26271 INSURER B: Erie Insurance Flagship City 35585 INSURER C: INSURER D: INSURER E: INSURER F:

**COVERAGES** **CERTIFICATE NUMBER:** CL13102303327 **REVISION NUMBER:**

THIS IS TO CERTIFY THAT THE POLICIES OF INSURANCE LISTED BELOW HAVE BEEN ISSUED TO THE INSURED NAMED ABOVE FOR THE POLICY PERIOD INDICATED. NOTWITHSTANDING ANY REQUIREMENT, TERM OR CONDITION OF ANY CONTRACT OR OTHER DOCUMENT WITH RESPECT TO WHICH THIS CERTIFICATE MAY BE ISSUED OR MAY PERTAIN, THE INSURANCE AFFORDED BY THE POLICIES DESCRIBED HEREIN IS SUBJECT TO ALL THE TERMS, EXCLUSIONS AND CONDITIONS OF SUCH POLICIES. LIMITS SHOWN MAY HAVE BEEN REDUCED BY PAID CLAIMS.

INSR LTR	TYPE OF INSURANCE	ACORD NUMBER	POLICY NUMBER	POLICY EFF. DATE (MM/DD/YYYY)	POLICY EXP. DATE (MM/DD/YYYY)	LIMITS
A	GENERAL LIABILITY <input checked="" type="checkbox"/> COMMERCIAL GENERAL LIABILITY <input type="checkbox"/> CLAIMS-MADE <input checked="" type="checkbox"/> OCCUR GENL AGGREGATE LIMIT APPLIES PER: <input type="checkbox"/> POLICY <input checked="" type="checkbox"/> PROJECT <input type="checkbox"/> LOC		048-2450219	12/24/2013	12/24/2014	EACH OCCURRENCE \$ 1,000,000 DAMAGE TO RENTED PREMISES (Per occurrence) \$ 1,000,000 MED EXP (Any one person) \$ 5,000 PERSONAL & ADV. INJURY \$ 1,000,000 GENERAL AGGREGATE \$ 2,000,000 PRODUCTS COMP. AGG \$ 2,000,000
A	AUTOMOBILE LIABILITY <input checked="" type="checkbox"/> ANY AUTO <input checked="" type="checkbox"/> ALL OWNED AUTOS <input checked="" type="checkbox"/> HIRED AUTOS <input checked="" type="checkbox"/> SCHEDULED AUTOS <input checked="" type="checkbox"/> NON-OWNED AUTOS		012-2440013	12/24/2013	12/24/2014	COMBINED SINGLE LIMIT (Per accident) \$ 1,000,000 BODILY INJURY (Per person) \$ BODILY INJURY (Per accident) \$ PROPERTY DAMAGE (Per accident) \$ Medical payments \$ 5,000
A	<input checked="" type="checkbox"/> UMBRELLA LIAB <input checked="" type="checkbox"/> OCCUR <input type="checkbox"/> EXCESS LIAB <input type="checkbox"/> CLAIMS-MADE DED RETENTION \$		036-2470052	12/24/2013	12/24/2014	EACH OCCURRENCE \$ 6,000,000 AGGREGATE \$ 6,000,000
B	WORKERS COMPENSATION AND EMPLOYERS LIABILITY ANY PROPRIETOR/PARTNER/EXECUTIVE OFFICER/MEMBER EXCLUDED? (Mandatory in IN) If yes, describe under DESCRIPTION OF OPERATIONS	Y/N N/A	096-7400023	12/24/2013	12/24/2014	<input checked="" type="checkbox"/> WC STATE TORY LIMITS <input type="checkbox"/> OTHER E.L. EACH ACCIDENT \$ 1,000,000 E.L. DISEASE - PER EMPLOYEE \$ 1,000,000 E.L. DISEASE - POLICY LIMIT \$ 1,000,000

DESCRIPTION OF OPERATIONS / LOCALS / VEHICLES (Attach ACORD 101. Additional Remarks Schedule, if more space is required)

<b>CERTIFICATE HOLDER</b>  Clients of Soumar Masonry Restoration, Inc.	<b>CANCELLATION</b>  SHOULD ANY OF THE ABOVE DESCRIBED POLICIES BE CANCELLED BEFORE THE EXPIRATION DATE THEREOF, NOTICE WILL BE DELIVERED IN ACCORDANCE WITH THE POLICY PROVISIONS.  AUTHORIZED REPRESENTATIVE  M Cardilli/SUSAN
---	--

ACORD 25 (2010/05)  
INS025 (2010/05)

© 1988-2010 ACORD CORPORATION. All rights reserved.

The ACORD name and logo are registered marks of ACORD.

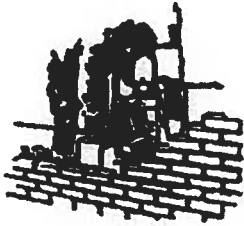

# Soumar Masonry Restoration, Inc.

"Serving Chicago, its suburbs, and the midwestern states for 60 years"

1033 S. Rt. 83 (Frontage Rd.)  
Elmhurst, IL 60126-4966  
Masonryres@aol.com

"See us at" www.soumar.com

1-800-737-8672  
630-834-3400  
Fax 630-834-3401

## References - Residential Light Commercial

Pg. 1 of 2

Since 1938, Soumar Masonry Restoration, Inc. has been servicing the exterior maintenance, repair and cleaning requirements of commercial, industrial, institutional and residential buildings in the Chicago Metropolitan area. We employ a seasonal staff of 8-15 employees skilled in masonry restoration for historical and contemporary buildings. We feel our size is small enough to give personal attention when needed yet big enough to serve larger scale projects when we are called upon. Our headquarters are centrally located in Elmhurst, IL. All buildings have unique properties and can weather in many ways. There are different levels of restoration, methods and techniques and styles of tuck pointing. Customers have varied interests regarding aesthetics and desired quality/cost. We treat each building as a unique project and will work with you to determine the existing condition and the recommended work needed. Please call us for any questions that you might have.

Ms. Jarczak 1535 Cuyler Berwyn, Ill	Rebuild top and bottom of wall north side and tuck point every mortar joint	Cell 708-484-4180
Greg Dejlitko G and M Metal 1970 Estes Elk Grove Village, Ill	East side new door openings, install block office, lintel install	Office 630-616-1126
Mr. Kosatka 27 W 676 Robin Lane West Chicago, Ill	Rebuild top half of chimney install a concrete cap	Home 630-231-0139
Mr. Kelly 3 N 463 Hickory Knoll Ln West Chicago, Ill	Rebuild top of chimney from roof up install a concrete cap	Cell 630-231-3809
Wally Mayer Interior Construction St. Thomas The Apostle Church 5471 S Kim bank Ave. Chicago, Ill	Lintel work, brick replacement, tuckpointing, caulking west wall	Office 847-593-6971 Cell 773-507-8393
Jerry Alvig Holy Cross Church 802 E Geneva Rd Wheaton, Ill	Tuckpointing, metal coping work, brick rebuilding	Office 630-665-1515 Cell 630 956-6379
Mr. Wally Hedei 4532 N River Road Schiller Park, Ill	Rebuild damaged window corner and lintel area west wall	Cell 708-453-0066
Mr. Musker 721 N Kensington La Grange, Ill	Grind out and tuck-point the three side of the house	Cell 312-258-6995
Doug Duncan Nations Roof 445 Sherman Evanston, Ill	Rebuild parapet wall around entire apartment complex, tuckpointing	Office 847-870-1133 Cell 312-666-6396
Ms. Nieman 990 Sheridan Highland Park, Ill	Rebuild the chimney from roof level up and install concrete cap	Home 847-432-9377
Mr. Schmidt Nandorf Company 4301 Midlothian Crestwood, Ill	Flashing work, lintels replace, tuck pointing, split face concrete block	Office 708-371-4242 Cell 708-704-4834
Mr. Bush house The Write Inn 211 N. Oak Park Ave. Oak park, Ill	Chimney rebuild, install retaining wall, tuckpointing	Office 708-383-4800 Cell 708-382-1412
Mr. JC Brown 107 W Hickory Chicago, Heights, Ill	Rebuild car damaged basement block wall and glass block window	Cell 708-957-2397
Mike Lellos Redevelopment Company 216-218 W Main Street West Chicago, Ill	Tuck-point the south wall, replace rusted lintel beam at garage opening	Office 630-665-0550 Cell 630-236-8880
Mr. Chapman Lake Mills Apartments 515-525 High view Addison, Ill	Rebuild chimney, install new opening for flue connection	Cell 630-816-2499
Jim Capuano Phoenix Veterans Printing 10430 Argonne Woods Dr Woodridge, Ill	Replace damaged concrete/steel bollard and concrete infill repairs	Office 630 410-0260
Mr. Bill Reardon 2636 N Francisco Chicago, Ill	Rebuild chimney an parapet walls north and south an tuck pointing	Cell 630 217-6495
Mr. Maxwell 289 Churchill Pl. Clarendon Hills, Ill	Tuck pointing entire house, buff color , red face brick smooth	Cell 630-240-4857 Home 630-655-9202
Ms. Samel 801 Robin hood La Grange Park, Ill	Rebuild chimneys from roof up with concrete caps	Home 708-352-8583 Niece 708-227-0126
Ms. Airdo 386 S. Washington St. Elmhurst, Ill	Cut out and tuck-point natural stone in grooved tuck pointing style	Home 630-833-8445 Cell 630-962-9354
Mr. Greg Johnson 1116 Grove Downers Grove, Ill	Cutout all mortar joints and tuck-point entire house	Home 630-852-7693
Steuertle Funeral Home- Mr. Eberling 350 S. Ardmore Villa Park, Ill	Tuck-point entire rear wall common brick, natural very light buff	Business 630-832-4161
Ms. Espinosa 3 Kingston Dr. Oak Brook, Ill	Dismantle and rebuild entire front courtyard arched walls in new brick	Home 630-880-3580
Mr. Catanzaro 2333 S. 21 ave Broadview, Ill	Dismantle and rebuild the chimney stack from roof level up	Home 708-344-8120
Ms. Innocenti 716 Acorn Hill Ln Oak Brook, Ill	Rebuild the entire chimney from roof up and installed as new concrete cap.	Home 630-986-0315
Mr. Jerry Kosoglad 268 Moraine Highland Park, Ill	Rebuild the top of chimney stacks and new concrete cap. Brick tuck-point	Cell 847-542-6200 Home 847-459-9700
Ms. Abrams 600 Sheridan Glencoe, Ill	Tuck pointing around fence and building. Rebuild fence pillars	Cell 312-813-0158 Home 847-433-6950
Bill Beach 1952 N. Howe Chicago, Ill 60614	Rebuild chimney , parapet walls on garage, tuck pointing	Cell 312-642-5667

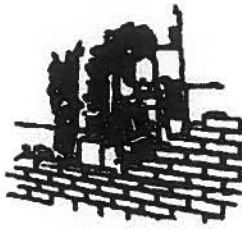

# Soumar Masonry Restoration, Inc.

"Serving Chicago, its suburbs, and the midwestern states for 60 years"

1088 S. Rt. 83 (Frontage Rd.)  
 Elmhurst, IL 60126-4966  
 Masonryres@aol.com

"See us at" www.soumar.com

1-800-737-8672  
 630-834-3400  
 Fax 630-834-3401

## References - Residential Light Commercial

Pg. 2 of 2

Mr. Tom Kieft 7290 Franklin Forest Park, Ill	Tuck pointing around house	Cell 312-613-9353
Ms. Bratton 830 S. Bell Chicago, Ill	Remove and replace glass block windows and new flashing installation	Home 312-552-1210
Ms. Lukaszewicz 432 S. Kensington La Grange, Ill	Dismantle and rebuild chimney	Cell 312-424-9113
Mr. Campbell 540 S. Berkley Elmhurst, Ill	Dismantle and rebuild chimney	Cell 312-205-2713
Mr. Fitzgerald 1051 Candlewood Downers Grove, Ill	Dismantle and rebuild privacy wall, masonry staining	630-969-3326
Ms. Jurvich 501 N. Spring La Grange Park, Ill	Chimney work, tuckpointing and stone work at home and church	Work 708-352-0168 Home
Ms. Messmer 129 W. Quincy Westmont, Ill	Brick work, tuckpointing and lintel work around house	Home 630-968-2429
Ms. Spiro 1512 Oak Dale Chicago, Ill	Tuckpointing and lintel flashing repairs. Water repellent install	Cell 847-271-9700
Ms. Frederickson 129 Melrose Elmhurst, Ill	Concrete work and masonry rebuild and tuckpointing around house	Home 630-279-1942
Mr. Phera 1111 Park Ln Western Springs, Ill	Chimney tuckpointing, repairs, stone work around house	Cell 708-246-4115
Ms. Vanderwayden 13 Whittington Course St. Charles, Ill	Dismantle masonry chimney and install decorative siding and cap	Home 630-377-8515
Mr. Behr 28 W 266 Warrenville Rd. Warrenville, Ill	Tuck pointing, caulking block repairs/rebuilding	630-351-0003 shop
Mr. Krzyowski 5227 Main St. Downer Grove, Ill	Tuck pointing entire front of commercial building	630-881-4116 Cell
Katie Porter 255 Laura Addison, Ill	Tuck pointing, brick work commercial building	630-988-2152 cell
Mr. Koziol 1010 S. State St. Lockport, Ill	Install new lintel and rebuild front parapet	815-838-9852 cell
Mr. Kaminski 6436 W 27 Th Pl Berwyn, Ill	Tuck pointing and rebuilding, lintel replacement	630-355-7206
Gerhart Schmeitekopf 1045 Garfield Oak park, IL	Tuckpointing, brick work, rebuild front	708-848-5406
Mr. Smith 420 E. Stimmel West Chicago, Ill	Chimney- rebuild	630-417-0864 cell
Mald Rodgers 1001 Business Center Dr. Mt. Prospect, IL	Saw cut out and tuck-point around building. Commercial Building	847-635-0044 x 213
Mike Drake c/o Schwall Buiden 181 Hawthorn Glencoe, Ill	Chimney tuckpointing and brick replacement	847-732-6888
Gloria Torson 272 W St. Charles Rd. Elmhurst, Ill	Lintels replacement and brick work	630-834-4822
Harmer Stepanek 27 W 084 Fierling Winfield, Ill	Chimney work and tuck pointing	630-663-9271
Brett Norris 25-27-29 Prospect Park Ridge, IL	Terra Cotta, brickwork, tuck pointing	847-721-0340
Gary Eppling 619 E Praire Ave. Wheaton, Ill	Chimney and stone work	630-784-0181
Wayne Kramer 225 Prospect Elmhurst, Ill	Window alterations, brick work	630-676-4953
Ruth Dalenberg 1030 Revers Ct Lombard, Ill	Chimney rebuilding new concrete cap	630-627-9556
Mr. Daeschler 214 E. Liberty St. Barrington, Ill	Exterior masonry, basement tuck pointing stone work	847-381-1310
Doug Flala 4015 Eberly Ave Brookfield, Ill	Car damage masonry rebuilding, glass block work, lintels work	708-486-7774
Jackie Gibson 1561 Camden Pl Wheaton, Ill	Chimney concrete cap and tuck pointing	630347-0316
Ms Levine 2619 York Rd. Oak Brook, Ill	Foundation cracks, tuckpointing	630-572-0562
Ms Lucas 3830 Ellington Ave. Western Springs, Ill	Glass block, tuck pointing, brick work	708-408-2309



**MIDLAND  
MASONRY  
INC.**

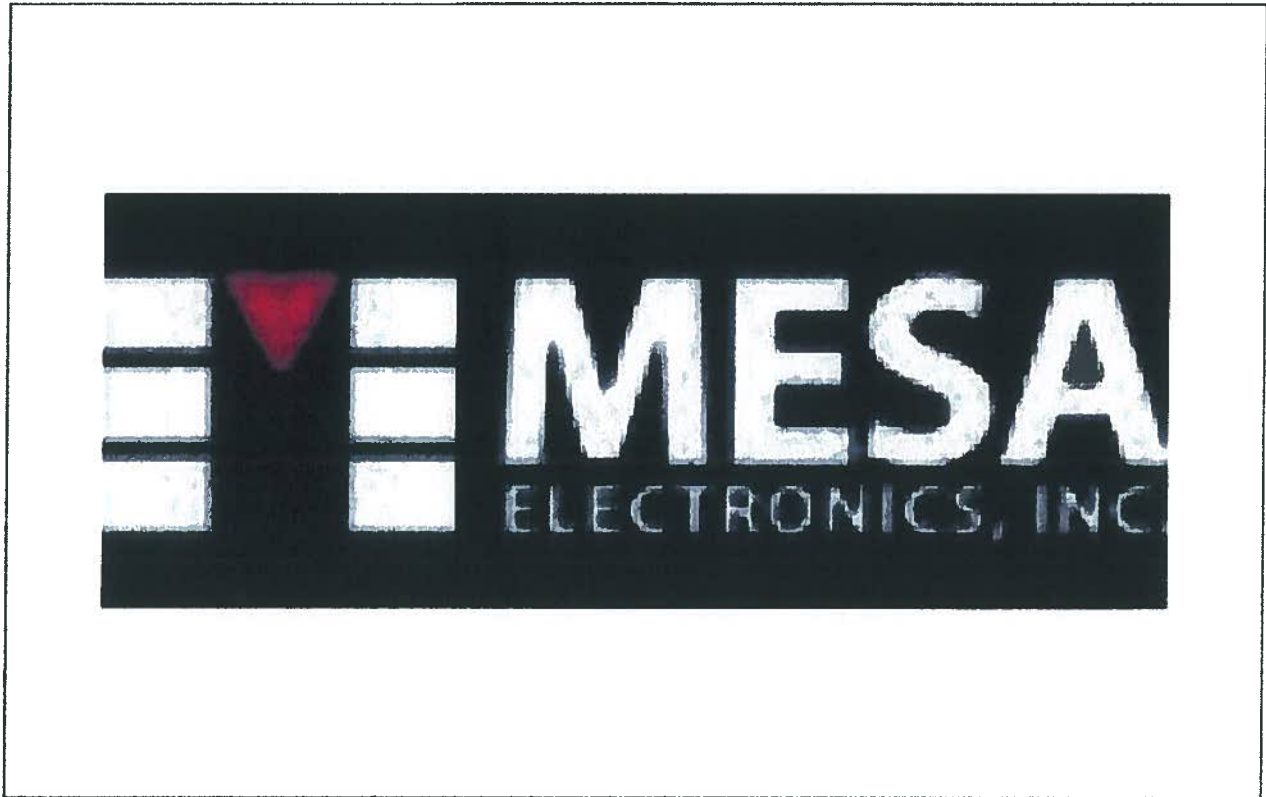

# Project Proposal

Date: July 24, 2014 REVISED AUGUST 29,2014

Project Proposal Number: 14-606

Prepared For: Andrew Howell - Mesa Electronics

C: 630-715-7894 Email: [ahowell@mesaelectronics.com](mailto:ahowell@mesaelectronics.com)

Project Name and Address: Mesa Electronics - 130-134 E Saint Charles Road, Lombard, IL. 60148



## **SCOPE OF WORK**

### ***Masonry Construction***

- Visually survey property/site for safety hazards.
- Lay out plastic tarps for lawn, garden, roof and siding for preventative measures during construction process.

### **West Elevation**

- Provide (4) new window openings. Bid includes masonry demolition, masonry infill, new precast sills, and steel lintel at (4) locations.

### **East Elevation**

- NO WORK.

### **South Elevation**

- Furnish and install (4) new brick columns. Bid includes (4) concrete/ steel angle supports to carry (4) new brick piers.
- Provide reworking of (3) large window openings. Bid includes complete demolition of (1) large opening, furnish and install new steel beam at (1) large opening. Minor tooting at (3) large openings, minor demolition at (3) large openings, and masonry infill at (3) large windows.
- Furnish and install precast sills, precast header, precast fascia units, and precast coping units on South elevation.
- Furnish and install new masonry stucco coat directly to existing C.M.U. on upper South elevation.
- Final sweep clean of job site and haul away all debris.

## **BID TOTAL**

**For total price of:**

***Fifty One Thousand Four Hundred Dollars.....\$51,400.00***

**Acceptance Date:** \_\_\_\_\_

**Signature:** \_\_\_\_\_

**Terms of Contract:**

Initial Payment of 33% due at job site staging and material delivery. Final due within ten (10) days of completed contracted work. There will be a 1 1/2% charge per thirty (30) days for past due invoices. Contractor, and/or Condo Association, and/or Owner agree(s) to pay any and call collection and/or attorney's fees for collection of money.

Base bid is for the above stated scope of work. Any deviation or alteration of the contract, will require a change order and may be subject to any charges associated with the outlined changes.

Base bid does not include any charges associated with city permit fees, performance bonds, shop drawings or engineering services, if required. Any and all additional costs over base bid, will be submitted for approval prior to payment.

Midland Masonry inc. is not responsible for prior or unseen damages at time of visual inspection and may withdraw proposal if not accepted within (30) days.



THIS CERTIFICATE IS ISSUED AS A MATTER OF INFORMATION ONLY AND CONFERS NO RIGHTS UPON THE CERTIFICATE HOLDER. THIS CERTIFICATE DOES NOT AFFIRMATIVELY OR NEGATIVELY AMEND, EXTEND OR ALTER THE COVERAGE AFFORDED BY THE POLICIES BELOW. THIS CERTIFICATE OF INSURANCE DOES NOT CONSTITUTE A CONTRACT BETWEEN THE ISSUING INSURER(S), AUTHORIZED REPRESENTATIVE OR PRODUCER, AND THE CERTIFICATE HOLDER.

**IMPORTANT:** If the certificate holder is an ADDITIONAL INSURED, the policy(ies) must be endorsed. If SUBROGATION IS WAIVED, subject to the terms and conditions of the policy, certain policies may require an endorsement. A statement on this certificate does not confer rights to the certificate holder in lieu of such endorsement(s).

<b>PRODUCER</b> Evans Insurance Agency, Inc. 500 Pennsylvania Ave, Box 440 Glen Ellyn, IL 60135-0440 www.evansinsurance.com	<b>AGENT</b> Steve Evans Phone: 630-460-1560 FAX: 630-460-1567 License No.: License State:
<b>INSURED</b> Midland Masonry, Inc. 110 W. Monroe Street Villa Park, IL 60181-3141	<b>INSURANCE AFFORDED COVERAGE</b> INSURER A: Peitch Insurance INSURER B: Travelers Indemnity Company INSURER C: INSURER D: INSURER E: INSURER F:

**COVERAGES**      **CERTIFICATE NUMBER:** 3513      **REVISION NUMBER:**

THIS IS TO CERTIFY THAT THE POLICIES OF INSURANCE LISTED BELOW HAVE BEEN ISSUED TO THE INSURED NAMED ABOVE FOR THE POLICY PERIOD INDICATED. NOTWITHSTANDING ANY REQUIREMENT, TERM OR CONDITION OF ANY CONTRACT OR OTHER DOCUMENT WITH RESPECT TO WHICH THIS CERTIFICATE MAY BE ISSUED OR MAY PERTAIN, THE INSURANCE AFFORDED BY THE POLICIES DESCRIBED HEREIN IS SUBJECT TO ALL THE TERMS, EXCLUSIONS AND CONDITIONS OF SUCH POLICIES. LIMITS SHOWN MAY HAVE BEEN REDUCED BY PAID CLAIMS.

TYPE	TYPE OF INSURANCE	DATE WHEN POLICY BEGINS	DATE WHEN POLICY ENDS	POLICY NUMBER	POLICY BIP (EFFECTIVE DATE)	POLICY EXP (EXPIRES)	LIMITS
A	GENERAL LIABILITY <input checked="" type="checkbox"/> COMMERCIAL GENERAL LIABILITY <input type="checkbox"/> CLAIMS-MADE <input checked="" type="checkbox"/> OCCUR GEN'L AGGREGATE LIMIT APPLIES FOR: <input checked="" type="checkbox"/> POLICY <input type="checkbox"/> PER <input type="checkbox"/> AGG	Y		CL0118832	2/03/2013	2/03/2014	EACH OCCURRENCE \$ 1,000,000 DAMAGE TO RENTED PREMISES (EA OCCUR) \$ 100,000 MED EXP (PER OR PERIS) \$ 5,000 PERSONAL & ADV INJURY \$ 1,000,000 GENERAL AGGREGATE \$ 2,000,000 PRODUCTS - COMP/OP AGG \$ 2,000,000
	AUTOMOBILE LIABILITY <input type="checkbox"/> ANY AUTO <input type="checkbox"/> ALL OWNED AUTOS <input type="checkbox"/> SCHEDULED AUTOS <input type="checkbox"/> HIRED AUTOS <input type="checkbox"/> NON-OWNED AUTOS						
A	<input checked="" type="checkbox"/> UMBRELLA LMB <input type="checkbox"/> EXCESS LMB <input type="checkbox"/> RET. \$ 10,000				2/03/2013	2/03/2014	EACH OCCURRENCE \$ 1,000,000 AGGREGATE \$ 1,000,000
B	WORKERS COMPENSATION AND EMPLOYERS LIABILITY ANY EMPLOYEE OR PART-TIME EXECUTIVE OFFICER/OWNER IS EXCLUDED? (Necessary in NY) If yes, describe under DESCRIPTION OF OPERATIONS NOTE	Y/N	N/A	0JUS040186412	2/10/2013	2/10/2014	B.L. EACH ACCIDENT \$ 1,000,000 B.L. DISEASE - EA EMPLOYEE \$ 1,000,000 B.L. DISEASE - POLICY LIMIT \$ 1,000,000

**DESCRIPTION OF OPERATIONS / LOCATIONS / VEHICLES** (Attach ADDENDUM for Additional Remarks Schedules, if more space is required)  
 Certificate holder listed as additional insured with respect to work done by named insured.

<b>CERTIFICATE HOLDER</b> Steve Evans	<b>CANCELLATION</b> SHOULD ANY OF THE ABOVE DESCRIBED POLICIES BE CANCELLED BEFORE THE EXPIRATION DATE THEREOF, NOTICE WILL BE DELIVERED IN ACCORDANCE WITH THE POLICY PROVISIONS. AUTHORIZED REPRESENTATIVE Steven J. Evans      3082
--	---







**SUPERIOR MASONRY, INC.**

**26 W 361 Burdette**

**Carol Stream, IL 60188**

**OFFICE: (630) 514-4872**

**FAX: (630) 517-8080**

*Email: [superiormasonry@comcast.net](mailto:superiormasonry@comcast.net)*

*Website: [www.superiormasonryinc.net](http://www.superiormasonryinc.net)*

8/14/14

**REVISED ESTIMATE**

**PROPOSAL SUBMITTED TO:**

**WORK TO BE PERFORMED AT:**

Henry Mesa  
hmesa@mesaelectronics.com

Mesa Electronics Blueprint, Sheet A201  
St. Charles Rd  
Lombard, IL

We hereby propose to furnish the materials and perform the labor necessary for the completion of the following:

- Bid includes additional work to be done on front entrance, west elevation, and office windows, as reviewed on site.
- Bid includes window and door adjustments and eifs on south elevation. Eifs to only have 2 projections at top of wall, with 4 projected brick columns.
- **Bid does not include any work to be done on east side of building.**
- All new brick will be matched as close as possible to existing by Illinois Brick.
- Superior Masonry, Inc. will not be responsible for dumpsters, caulking, or any minor damage done to landscaping due to construction.

**Bid does not include permit fees, if applicable.** Superior Masonry, Inc. will provide certificate of insurance and bond only after receiving signed contract. Failure on our part to do so will void signed contract. Any alteration or deviation from above specifications involving extra costs will be executed only upon **WRITTEN ORDER**, and will become an **EXTRA CHARGE** over and above the estimate. All agreements are contingent upon strikes, accidents or delays beyond our control. All labor is guaranteed to be as specified and completed in a substantial workmanlike manner according to International Masonry Institute standards for the amount of:

**THIRTY SIX THOUSAND THREE HUNDRED TWENTY FIVE AND 00/100**

**\$36,325.00**

**40% Deposit due upon acceptance of signed contract.** Material can not be ordered until deposit is received. If job exceeds 30 days, additional payment equal to % of job complete is due; remaining balance is due upon completion of masonry construction. If final payment is not received within 45 days a **Mechanics Lien** will be initiated against the property owners and interest will accrue at 1.5% monthly. Any and all attorney fees, and or court costs incurred by Superior Masonry Inc. to collect such debt will be the responsibility of property owner. Above prices, specifications and conditions are satisfactory and are hereby accepted. You are authorized to do the work as specified. **THIS QUOTE IS GOOD FOR ONLY 60 DAYS.**

Date \_\_\_\_\_

Signature \_\_\_\_\_ Signature \_\_\_\_\_

122305

# Carlson Glass

## Estimate

312 West Front Street  
Wheaton, Illinois 60187

Customer's PO :

Printed at: 8/12/2014 11:47 am

(630) 668-7234 Voice (630) 462-4473 Fax carlsonsglass@sbcglobal.net

Billing Address:

Billing address ID: 59266

**Mesa, Henry**  
411 S. 2nd Street  
St Charles, IL 60174

Phone Number: Who to contact:  
at address: 630-880-9443 Henry Mesa  
A:  
B:

Billing account: | Taxable: Yes Tax Number:

Job Address:

**Mesa Electronics,**  
130 E. St. Charles Road  
Lombard, IL 60148

Phone Number: Who to contact:  
at address: 630-880-9443 Henry Mesa  
A:  
B:

Billing account: | Taxable: Yes Tax Number:

HMesa@Mesaelectronics.com

### Workord Item

#### Alternative 1

Quantity	Size	Note
1		<p>Change all existing windows to new Kawneer thermally broken aluminum frames with Hi performance soft coat Low E clear insulating glass. The new frames will be bronze anodized.</p> <p>18 windows, tempered as required by code.</p> <p>7 - 7' x 7' 2 - 7' x 3' 7 - 5' x 4' 1 - 10' x 4' 1 - 11' x 7'</p> <p>Supply and install 2 pairs of entry doors. The doors will have overhead closers, MS dead bolt locks with interior thumb turns, tubular push/pulls, one pair of butt hinges per leaf, bottom threshold and sweep.</p> <p>Demo and dispose of existing glass and metal. Installed including tax</p>

Quantity	Size	Note
1		<p>Please Note: Low E is a coating on the glass providing UV protection and an increased "R" value. Low E glass has a slight tint and may appear to have a haze in certain light conditions. Color variation due to different manufacturing, unit orientation or light conditions are to be expected.</p> <p>Standard Hard Coat Low E insulating glass is available at a reduced price. Hard coat Low E is not as energy efficient as the soft coat.</p>

**Subtotal for Alt # 1:**

Subtotal for Alt # 1  
**\$41,254.10**

#### Alternative 2

Int : 122305

Mesa Electronics, => 130 E. St. Charles Road, Lombard

Quantity	Size	Note
1		Alternative Add for 3rd pair of doors. Opening supplied by others.

**Subtotal for Alt # 2 :**

Subtotal for Alt # 2  
**\$3,325.00**

**Alternative 3**

Quantity	Size	Note
1		Remove existing doors and windows as needed. Supply and install new doors and windows in new masonry openings supplied by others. Kawneer thermally broken aluminum frames with high performance soft coat Low E clear insulating glass. The new frames will be bronze anodized. 20 windows, tempered as per code. 6 - 6' x 6' 5 - 4' x 5' 1 - 10' x 7' 8 - 6'6" x 7' 3 pairs of doors with transom frames. The doors will have overhead closers, MS deadbolt locks with interior thumb turns, tubular push/pull, one pair of butt hinges per leaf, bottom threshold and sweep. Installed including tax

Quantity	Size	Note
1		Please Note: Low E is a coating on the glass providing UV protection and an increased "R" value. Low E glass has a slight tint and may appear to have a haze in certain light conditions. Color variation due to different manufacturing, unit orientation or light conditions are to be expected.  Standard Hard Coat Low E insulating glass is available at a reduced price. Hard coat Low E is not as energy efficient as the soft coat.

**Subtotal for Alt # 3 :**

Subtotal for Alt # 3  
**\$49,900.29**

Total Items Total  
**\$94,479.39**

504

Jnt : 122305

Mesa Electronics, => 130 E. St. Charles Road, Lombard

**We Propose hereby to furnish material and labor, complete in accordance with above specifications, For the Sum of:**

**\$94,479.39**

**Authorized Signature** \_\_\_\_\_

To place or verify this order: Please return one signed copy of this form and a required deposit of : \$47,239.70

Please write on the returned copy or call, fax or e-mail us with any releveant PO#s or identifying job names that apply to this work.

All Material is guaranteed to be as specified. All work to be completed in a workmanlike manner according to standard practices. Any alteration, deviation or upon disassembly, we reveal additional work, from above specifications, involving extra costs will be executed only upon customer approval, and will become an extra charge over and above the estimate. All agreements contingent upon strikes, economics, accidents, delays beyond our control. Owner to carry fire, tornado and other necessary insurance. Our workers are fully covered by Workmen's Compensation Insurance. This material and or work is subject to applicable taxes, misc. freight, delivery, environmental, equipment rental and service supply charges. Condo association, local association or governing bodies' permissions, permits, approvals, requirements, or fees are customer responsibility. Your measurements are your responsibility. Our measurements if any may require a final measure or pattern before ordering.

**Date / / Signature** \_\_\_\_\_

Price is subject to change after 60 days.

Acceptance of Proposal -- The above prices, specifications and conditions are satisfactory and hereby accepted.

You are authorized to do the work as specified.

Final payment of total balance is to be made on completion.

# **A&G Glass & Mirror, Inc.**

501 W. Roosevelt Road

630-231-2340

phone [aandglass@hotmail.com](mailto:aandglass@hotmail.com)

West Chicago, IL 60185

630-231-3356 fax

Estimate prepared by: Dustin Frohling

## **Proposal**

Submitted to: Andrew Howell

Date: August 28, 2014

Job Name: Mesa Electronics

Job Location: Lombard

### **Storefront**

All storefront made from YKK 2" x 4 ½" thermally broken material, #17 clear anodized finish.

All openings to have head receptor and sill.

All glass to be 1" clear low E insulated glass to meet Illinois .35 Uvalue standards, tempered where required.

### **Openings to be divided per plans**

6- approx. 72" x 67" punched openings

2- approx. 336" x 84"

1- approx. 240" x 84"

1- approx. 60" x 103", door sidelite

1- approx. 36" x 103", door sidelite

1- approx. 130 x 84

3-6'0 x 7'0 YKK narrow style doors with transom. #17 clear anodized finish, offset pivots, concealed rod exit device. Standard surface mounted closer. To be glazed with 1" clear low E tempered insulated units.

\*Price does not include: brickwork, drywall, painting, electric, etc.

**\$35,000.00 installed with tax (clear anodized finish)**

**Add 1.5 percent for dark bronze anodized finish**

**Add ten percent for painted finish**

\_\_\_\_\_ Date \_\_\_\_/\_\_\_\_/\_\_\_\_\_  
Acceptance of Proposal

Note: Work cannot proceed until we have a signed authorization of Proposal. Any alteration or deviation from above specifications involving extra charge over and above the estimate. All agreements contingent upon strikes, accidents or delays beyond our control.

This proposal may be withdrawn by is if not accepted within 60 days. By signing this proposal you are accepting and guaranteeing payment of the invoice, you are also agreeing to pay attorney fees and court

# E & T Glass and Mirror Inc.

Date: 8/19/2014

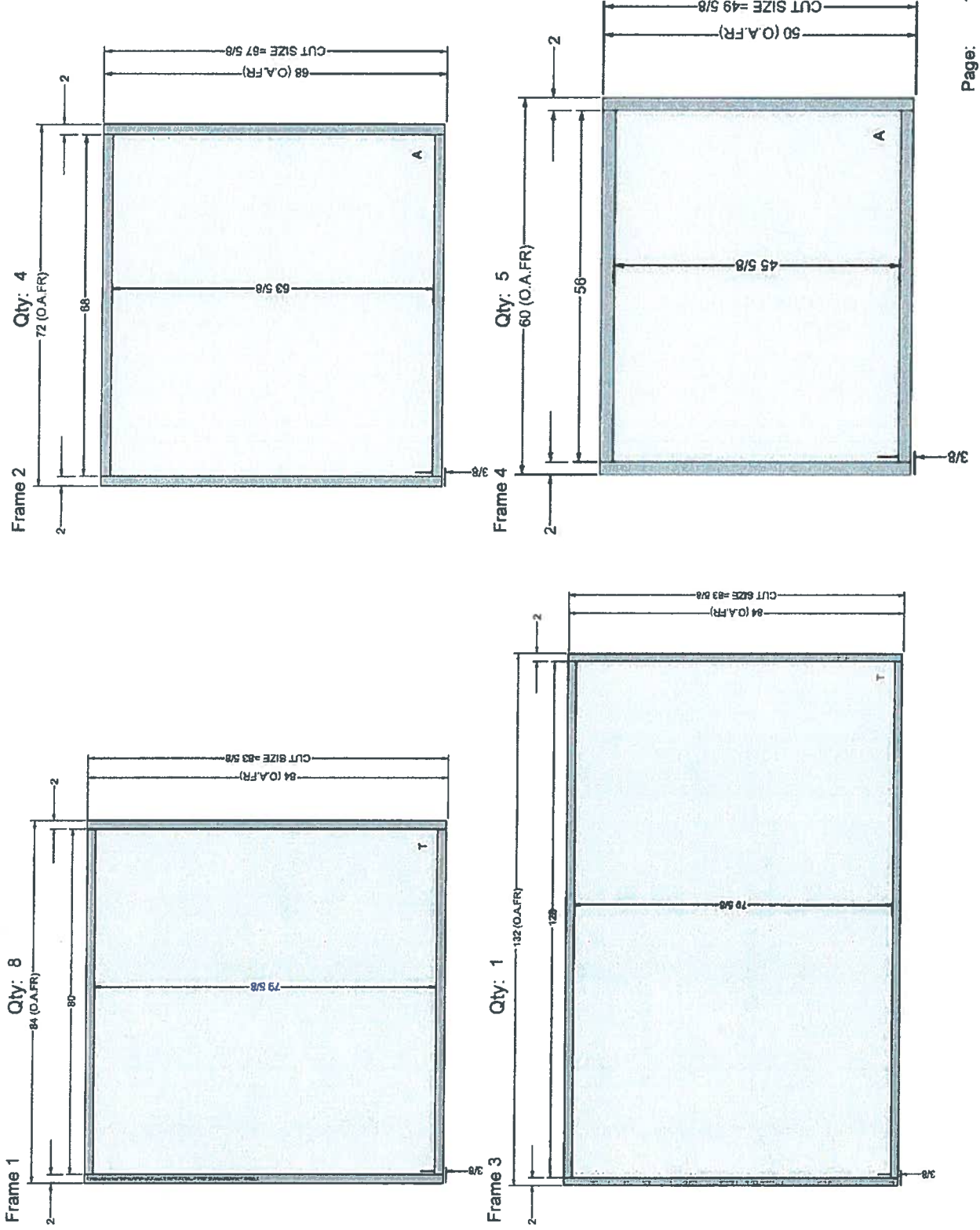



# E & T Glass and Mirror Inc.

Date: 8/19/2014

Frame 5 Qty: 2

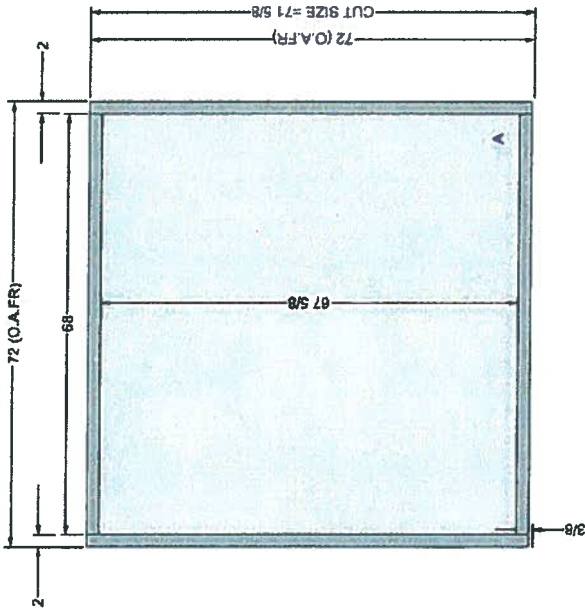

Frame 6 Qty: 2

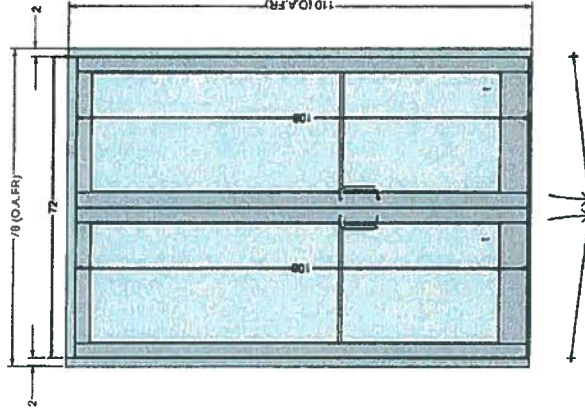

Frame 7 Qty: 1

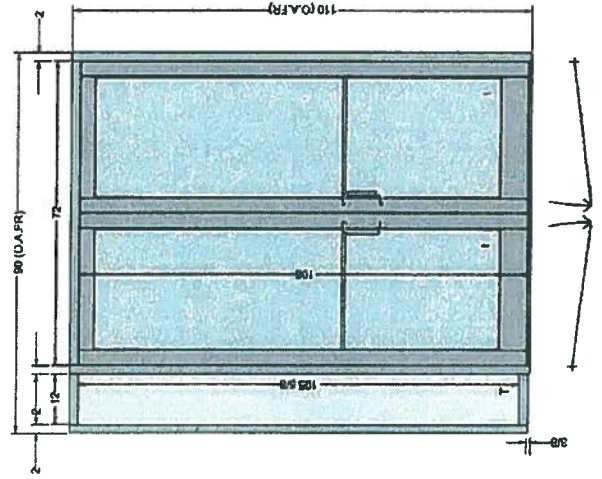

PROJECT: Mesa Electronics

ESTIMATE #: 081514-1

PROJECT TOTAL: \$47,089.00

Includes freight, surcharges  
Includes sales tax, glazing labor

PROJECT DETAILS: Finish = #17 Clear Anodized

DOORS: 350 Medium Stile, standard rail and stile dimensions

Hardware to include offset pivots, MS1850 locks, C09/CP push-pull sets, standard thresholds and sweeps

DOOR FRAME: TF551-CG filler-back door frame

FRAMING:

TF451T-CG 2" x 4-1/2" thermal framing

GLASS:

T = 1" O.A. IGU ~ SN68(2) on 6mm Clear TE / 6mm Clear TE

A = 1" O.A. IGU ~ SN68(2) on 6mm Clear AN / 6mm Clear AN

ESTIMATED BY: TS

DEDUCT \$2,139.00 for 7' doors w/ transom



FOX VALLEY FENCE & SUPPLY  
815-787-9821  
FAX 815-787-7894

August 28, 2014

Mesa Electronics - Lombard

**Removal and replacement of 40' of chain link fence and gates:**

We are pleased to submit our proposal to furnish and install the following equipment.

**Replace chain link fence with 4' steel majestic ornamental fence.**

-Includes a 14' wide gate and an operator.

*Investment . . . . . \$16,005.96*

**NOTES:**

- \* All conduits and concrete work is by others unless specifically listed in above proposal.
- \* All utilities both public & private, Not signatory to J.U.L.I.E. must be located by customer prior to start of any work.
  - We will not be responsible for damage to utilities not located.
- \* Payment / performance bonds / permits are not included. If required the associated costs will be additional.
- \* Investment includes necessary taxes to ECI's suppliers, freight, one year warranty on parts and labor.

Thank you for the opportunity to submit this proposal. We look forward to working with you on this project. Please call if you have any questions.

Customer acceptance:  
(please sign and date)



**NORTHERN ILLINOIS FENCE, INC.**

320 WEST LINCOLN HIGHWAY

CORTLAND, IL 60112

815-756-3561 phone

815-756-7920 fax

To: Emma Olson  
Phone: (630)443-6683  
Email: Eolson@mesaelectronics.com  
Site: Lombard Parking Lot  
Address: 130 East St. Charles St.  
Lombard, IL 60148

NIF Quote Number: N37090-1

Description: Take down and replace existing 6' high chain link fence with new 4' tall ornamental fence from options listed below. Fence to be 4' tall and included 1 14'-6" wide cantilever gate with operator.

Northern Illinois Fence agrees to provide labor and material to remove existing fence and install new 4' tall ornamental fence from one of the options listed below.

**Scope of work includes:**

- Public Utility Locates
- Removal and installation through asphalt
- 2 Pipe bollards for protection of gas meter at gate
- Dealing with stumps grown into fence and footings
- All post set 36" in new concrete footing

**Option 1(Mont. Plus – Majestic style steel ornamental fence) \$14,810.00**

**Option 2 (Elite EFF20 industrial grade aluminum fence) \$13,810.00**

**Exclusion Beyond Items and Clarifications:**

- Fence permit
- Plat of survey will be supplied to NIF to aid in location of property irons
- Installation of electrical service for new slide gate operator

Thanks for the opportunity to bid on your project. If you have any questions please feel free to give me a call or send me an email.

Jeremy Knobeloch  
Northern Illinois Fence/Complete Fence  
Commercial Sales  
Office: (815)756-3561  
Mobile: (630)881-8050

Customer Signature \_\_\_\_\_ Date: \_\_\_\_\_

NIF rep Signature Jeremy Knobeloch Date: 8/28/2014

# *Complete Fence*

"WHERE QUALITY COUNTS"  
27W174 Rt. 64 (North Ave.)  
West Chicago, IL 60185  
630-231-9550 phone  
630-231-0079 fax

Hello Emma,

Complete Fence agrees to remove and replace the 40' of chain link fence with existing gate on the west property line with 4' steel fence.

Remove existing perimeter fence and 2 dumpster enclosures  
**Cost: \$15,800.50**

Bid includes an operator and bollards as discussed. All work to be non-union. Gate will be 14.5' wide opening. All electric is by others. Removed fence material will be left onsite for customer to dispose of.

Customer Signature \_\_\_\_\_ Date: \_\_\_\_\_  
8/28/2014

**RESOLUTION**  
**R \_\_\_\_\_**

**A RESOLUTION APPROVING A DOWNTOWN IMPROVEMENT AND  
RENOVATION GRANT FOR THE PROPERTY COMMONLY KNOWN AS  
130 E. ST. CHARLES ROAD**

WHEREAS, the Village disburses funds for the Downtown Improvement and Renovation Grant Program (the "Program") under the authority of the Village Board of Trustees, and will provide monetary grants to qualified property owners in the Lombard Tax Increment Financing (TIF) St. Charles Road West District to enhance and improve buildings and parking areas; and,

WHEREAS, Enrique and Lori Mesa (the "Applicants"), wish to participate in this Program for façade renovations to the building (the "Project") located at 130 E. St. Charles Road, Lombard, Illinois (the "Subject Property") and,

WHEREAS, the Applicants are also the owners of 130 E. St. Charles Road, Lombard, Illinois; and,

WHEREAS, the Project shall consist of those renovations to the façade of the building on the Subject Property as set forth on Exhibit "A" attached hereto and made part hereof; and,

WHEREAS, the Project will complement and support the Village's plans to maintain a quality Central Business District;

NOW, THEREFORE, BE IT RESOLVED BY THE PRESIDENT AND BOARD OF TRUSTEES OF THE VILLAGE OF LOMBARD, DUPAGE COUNTY, ILLINOIS, as follows:

**SECTION 1:** That the Village shall provide the Applicants grant of up to forty-eight thousand five hundred one and 95/100 dollars (\$48,501.95), pursuant to the Program (the "Grant"). Such grant monies shall be available to the Applicants upon the authorization of the Village's Director of Community Development, after receipt of satisfactory evidence that the project components have been completed, and that the Applicants have paid all invoices for labor and materials in connection therewith.

**SECTION 2:** The Applicants, as well as any subsequent business or property owner, will perform the following obligations in connection with the Project:

- a. Expenditures relative to the Project must comply with the Illinois Prevailing Wage Act;
- b. Permits must be applied for and received for all of the work;
- c. Before the grant can be paid out, the Applicants will submit a final receipt (showing it is paid in full) and waivers of lien from the contractors; and

Resolution No. \_\_\_\_\_  
130 E. St. Charles Road

- d. That the Applicants shall not apply for a vacancy exemption from the York Township Assessor during the ten (10) year period following receipt of the Grant.

**SECTION 3:** The Applicants, and any subsequent business or property owner, shall be required to maintain the Property in accordance with all Village codes and ordinances, and obtain any and all necessary licenses and permits required relative thereto.

**SECTION 4:** That the Downtown Improvement and Renovation Grant Program Agreement, relative to the Project, attached hereto as Exhibit "B" and made part hereof is hereby approved (the "Agreement")

**SECTION 5:** The Village may terminate the Agreement if the Applicants, or any subsequent business or property owner, fails to comply with any of the terms of the Agreement. In the event of termination, the Applicants shall be required to repay any amount of the Grant disbursed.

**SECTION 6:** That the Village President and Village Clerk are hereby authorized and directed to sign, on behalf of the Village of Lombard, the Agreement attached hereto as Exhibit "B".

Adopted this \_\_\_\_ day of \_\_\_\_\_, 2014.

Ayes: \_\_\_\_\_

Nayes: \_\_\_\_\_

Absent: \_\_\_\_\_

Approved this \_\_\_\_ day of \_\_\_\_\_, 2014.

\_\_\_\_\_  
Keith T. Giagnorio  
Village President

ATTEST:

\_\_\_\_\_  
Sharon Kuderna  
Village Clerk

Resolution No. \_\_\_\_\_  
130 E. St. Charles Road

**EXHIBIT A**  
**Legal Description**

LOT 7 AND 8, BLOCK 19 IN H.O. STONE AND COMPANY'S  
ADDITION TO LOMBARD, A SUBDIVISION IN THE SOUTHWEST  
QUARTER OF SECTION 5 AND PART OF THE NORTHWEST  
QUARTER OF SECTION 8, TOWNSHIP 39 NORTH, RANGE 11  
EAST OF THIRD PRINCIPAL MERIDIAN, ACCORDING TO THE  
PLAT THEREOF RECORDED JUNE 26, 1924 AS DOCUMENT  
179463, IN DUPAGE COUNTY, ILLINOIS.

PIN 06-08-104-011

**EXHIBIT B**

**DOWNTOWN IMPROVEMENT AND RENOVATION GRANT PROGRAM  
AGREEMENT**

This Agreement is entered into this second day of October, 2014, by and between the Village of Lombard, Illinois, (hereinafter referred to as the "Village"), and Enrique and Lori Mesa (hereinafter referred to as "Applicants") doing business at 130 E. St. Charles Road, Lombard, Illinois (said location being legally described on Exhibit "1" attached hereto and made part hereof – hereinafter referred to as the "Subject Property"), with personal property being secured at 130 E. St. Charles Road, Lombard, Illinois. The Village and the Applicants are sometimes referred to herein collectively as the "Parties."

**WITNESSETH**

**WHEREAS**, the Village, pursuant to Sections 36.30 through 36.36 of the Lombard Village Code, has established a Downtown Improvement and Renovation Grant Program (hereinafter referred to as the "Program") and, as such, will provide grants to qualified business owners and property owners in the Eligible TIF Districts (as said term is defined in Section 36.31 of the Lombard Village Code) for exterior renovations; and

**WHEREAS**, the Program compliments and supports the Village's plans to maintain a quality Central Business District; and

**WHEREAS**, exterior renovations are desirable within the Central Business District and contribute to an economically strong Central Business District; a commercial area where the image, appearance, and environment encourage the attraction of shoppers; and

**WHEREAS**, the Applicants wish to participate in this Program for proposed exterior renovations to be located at 130 E. St. Charles Road, Lombard, Illinois; Program Application No.: **14-01**; with said exterior renovations being more specifically described in Exhibit "2" attached hereto and made part hereof (hereinafter referred to as the "Project");

**NOW, THEREFORE**, in consideration of the foregoing, and other good and valuable consideration, the receipt of which is hereby acknowledged by the Parties hereto, the Parties agree as follows:

**SECTION 1:** The Village shall provide the Applicants with a grant under the Program in an amount not to exceed forty-eight thousand, five hundred one and 95/100 dollars (\$48,501.95) (hereinafter referred to as the "Grant"). Such Grant shall be available to the Applicants upon the authorization of the Village's Director of Community Development, and after the Applicants has constructed the Project, and complied with the provisions of this Agreement and Sections 36.30 through 36.36 of the Lombard Village



Resolution No. \_\_\_\_\_  
130 E. St. Charles Road

Code, as well as paid for the Project. The maximum amount of the Grant, as set forth above, is based upon the Applicants expending no less than ninety seven thousand three and 89/100 dollars (\$97,003.89) in relation to the Project. In the event that the Applicants' expenditures for the Project are less, the Grant shall be reduced such that the maximum amount of the Grant shall not exceed fifty percent (50%) of the amount expended by the Applicants in relation to the Project.

**SECTION 2:** The Applicants shall undertake the following in connection with the Project:

- a. Expenditures relative to the Project must comply with the Illinois Prevailing Wage Act;
- b. Permits must be applied for and received for all of the work;
- c. Before the grant can be paid out, the Applicants will submit a final receipt (showing it is paid in full) and waivers of lien from the contractors; and
- d. That the Applicants shall not apply for a vacancy exemption from the York Township Assessor during the ten (10) year period following receipt of the Grant.

**SECTION 3:** Upon completion of the Project, the Applicants shall maintain the Subject Property and the business located thereon in accordance with all applicable federal, state and local laws, rules and regulations.

**SECTION 4:** The Applicants hereby consent to the recording of this Agreement to serve as notice to future purchasers, assigns, estate representatives, mortgagees, and all other interested persons of the conditions outlined in this Agreement.

**SECTION 5:** In the event the Village terminates this Agreement as a result of the Applicants failing to comply with any of the terms of this Agreement, the Applicants shall be required to repay any amount of the Grant that has been disbursed by the Village. In the event said amount is not repaid, the Village shall have the right to record a lien against the Subject Property for said amount.

**SECTION 6:** This Agreement shall be binding upon the successors and assigns of the Parties hereto.

VILLAGE OF LOMBARD

\_\_\_\_\_  
By: Keith T. Giagnorio, Village President

Resolution No. \_\_\_\_\_  
130 E. St. Charles Road

\_\_\_\_\_  
Attest: Sharon Kuderna, Village Clerk

APPLICANTS

\_\_\_\_\_  
Enrique Mesa

\_\_\_\_\_  
Lori Mesa

Resolution No. \_\_\_\_\_

130 E. St. Charles Road

STATE OF ILLINOIS        )  
   )SS  
 COUNTY OF DUPAGE        )

I, the undersigned, a Notary Public, in and for the County and State aforesaid, DO HEREBY CERTIFY that Keith T. Giagnorio, personally known to me to be the President of the Village of Lombard, and Sharon Kuderna, personally known to me to be the Village Clerk of said municipal corporation, and personally known to me to be the same persons whose names are subscribed to the foregoing instrument, appeared before me this day in person and severally acknowledged that as such President and Village Clerk, they signed and delivered the said instrument and caused the corporate seal of said municipal corporation to be affixed thereto, pursuant to authority given by the Board of Trustees of said municipal corporation, as their free and voluntary act, and as the free and voluntary act and deed of said municipal corporation, for the uses and purposes therein set forth.

GIVEN under my hand and official seal, this \_\_\_\_\_ day of \_\_\_\_\_, 2014.

Commission expires \_\_\_\_\_, 20\_\_\_\_\_.

\_\_\_\_\_  
 Notary Public

Resolution No. \_\_\_\_\_  
130 E. St. Charles Road

STATE OF ILLINOIS        )  
  )SS  
COUNTY OF DUPAGE        )

I, the undersigned, a Notary Public, in and for the County and State aforesaid, DO  
HEREBY CERTIFY that Enrique Mesa and Lori Mesa, personally known to me to be the  
same person whose names are subscribed to the foregoing instrument, appeared before  
me this day in person and severally acknowledged that they signed and delivered the said  
instrument, as their free and voluntary act, for the uses and purposes therein set forth.

GIVEN under my hand and official seal, this \_\_\_\_\_ day of \_\_\_\_\_, 2014.

Commission expires \_\_\_\_\_, 20\_\_\_\_\_.

\_\_\_\_\_  
Notary Public

Resolution No. \_\_\_\_\_  
130 E. St. Charles Road

**EXHIBIT 1**  
**Legal Description**

LOT 7 AND 8, BLOCK 19 IN H.O. STONE AND COMPANY'S  
ADDITION TO LOMBARD, A SUBDIVISION IN THE SOUTHWEST  
QUARTER OF SECTION 5 AND PART OF THE NORTHWEST  
QUARTER OF SECTION 8, TOWNSHIP 39 NORTH, RANGE 11  
EAST OF THIRD PRINCIPAL MERIDIAN, ACCORDING TO THE  
PLAT THEREOF RECORDED JUNE 26, 1924 AS DOCUMENT  
179463, IN DUPAGE COUNTY, ILLINOIS.

PIN 06-08-104-011

## **EXHIBIT 2**

The Community Development Department retains a copy of the submittal to the Economic and Community Development Committee. This submittal includes contractor's quotes and a description of the work to be completed. The Applicants propose to: install awnings, electric and gooseneck lighting, masonry work, new windows, and a decorative fence.

### *Awnings*

Mesa Electronics is seeking to install three black awnings on the south elevation.

### *Electric Service for External Illumination*

Mesa Electronics is seeking to install electric service for outside gooseneck lighting above the awnings.

### *Lighting*

Mesa Electronics is seeking to install outside gooseneck lighting above the awnings and sconces.

### *Masonry*

Mesa Electronics is seeking to change and update the building façade on the south and part of the west elevations to include additional compatible masonry, and an enhanced parapet wall with EIFS construction. Four new window openings will be installed on the south elevation, consistent with a typical retail storefront. The new brick color will be matched to the current brick. The front entrance would be ADA accessible.

### *Glass*

Mesa Electronics is seeking to install new windows on the south elevation.

### *North Exterior Perimeter Fence*

Mesa Electronics is seeking to install a new fence replacing the existing chain link fence on the property. The new fence will be a four feet tall ornamental style aluminum fence and which will help create an aesthetic enhancement for the corridor.