

VILLAGE OF LOMBARD
REQUEST FOR BOARD OF TRUSTEES ACTION
For Inclusion on Board Agenda

 X

Resolution or Ordinance (Blue) _____ *Waiver of First Requested*
Recommendations of Boards, Commissions & Committees (Green)
Other Business (Pink)

TO: PRESIDENT AND BOARD OF TRUSTEES

FROM: William T. Lichter, Village Manager

DATE: September 8, 2004 (B of T) Date: September 16, 2004

TITLE: PC 04-17: Text Amendments to the Zoning Ordinance

SUBMITTED BY: Department of Community Development

BACKGROUND/POLICY IMPLICATIONS:

Your Plan Commission transmits for your consideration its recommendation relative to the above-mentioned petition. This petition requests a text amendment to Section 155.210 of the Lombard Zoning Ordinance to modify the maximum permitted height, yard requirements and overall maximum size of accessory buildings and structures. (ALL DISTRICTS)

The Plan Commission recommended approval of this petition.

Fiscal Impact/Funding Source:

Review (as necessary):

Village Attorney X _____ Date _____
Finance Director X _____ Date _____
Village Manager X W. T. Lichter Date 9/8/04

NOTE: All materials must be submitted to and approved by the Village Manager's Office by 12:00 noon, Wednesday, prior to the Agenda Distribution.

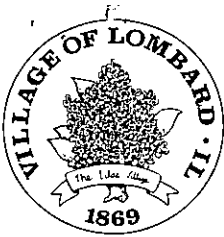

MEMORANDUM

TO: William T. Lichter, Village Manager

FROM: David A. Hulseberg, AICP, Director of Community Development *Delt*

DATE: September 16, 2004

SUBJECT: PC 04-17: Text Amendments to the Zoning Ordinance (Accessory Structures)

A proposed text amendment to the Zoning Ordinance pertaining to accessory structures was tabled at the July 22 and August 19 Board meetings and has been placed on the September 16, 2004 Village Board agenda.

As more than two Board meetings have passed since this item was first placed on the agenda, staff is providing the Board with a copies of the reports and correspondence associated with the petition, including:

1. Plan Commission referral letter;
2. IDRC reports for PC 04-17 (the initial report presented at the May 17 meeting and the supplemental report presented at the June 21 meeting);
3. A draft Ordinance granting approval of a text amendment to the Zoning Ordinance which modifies the maximum building height for accessory structures, capping the overall height at 17 feet;
4. A draft Ordinance granting approval of a text amendment to the Zoning Ordinance which caps the size of an accessory structure to 750 square feet of ground floor area;
5. A draft Ordinance granting approval of a text amendment to the Zoning Ordinance which modifies the setback requirements for accessory structures so that the setback requirements are the same regardless of whether recorded public utility easements are on the property.

The Plan Commission recommended approval of the petition. Staff has placed this item on the Agenda for Separate Action and will provide a PowerPoint presentation at the September 16, 2004 meeting.

As noted in the attached materials, the amendment to the accessory height requirement is in response to previous discussions by the Village Board. The amendment to decrease the maximum overall size of accessory structures was also based upon conversations with Board members. The amendment to increase the setback requirements for accessory structures is intended to standardize the setbacks for accessory structures on new lots of record (which require 5 foot side yard and 10 foot rear yard utility easements) and those properties without recorded easements.

H:\cd\worduser\pccases\2004\04-17\wtl referral memo 2.doc

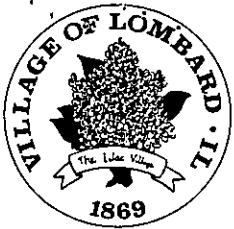

VILLAGE OF LOMBARD

255 E. Wilson Ave.
Lombard, Illinois 60148
630/620-5700 FAX: 630/620-8222
TDD: 630/620-5812
www.villageoflombard.org

Village President
William J. Mueller

July 22, 2004

Mr. William J. Mueller,
Village President, and
Board of Trustees
Village of Lombard

Trustees

Joan DeStephano, Dist. 1
Richard J. Tross, Dist. 2
Karen S. Koenig, Dist. 3
Steven D. Sebby, Dist. 4
Kenneth M. Florey, Dist. 5
Rick Soderstrom, Dist. 6

Subject: PC 04-17: Text Amendments to the Lombard Zoning Ordinance

Village Manager
William T. Lichter

Dear President and Trustees:

Your Plan Commission transmits for your consideration its recommendation regarding the above-referenced petition. The Village of Lombard requests amendments to the Zoning Ordinance to revise the maximum height, size and location of accessory structures in residential zoning districts.

After due notice and as required by law, the Plan Commission conducted public hearings for this petition on May 17, 2004 and June 21, 2004.

On May 17, 2004 William Heniff, Senior Planner, gave the staff report. He stated that two changes are proposed to the Zoning Ordinance. He indicated that staff has put together a number of text amendments for Plan Commission and Village Board consideration. Staff has brought forth these items to the Plan Commission in previous workshops for discussion. Staff is now looking at text amendments to modify the maximum allowable height, size, and yard requirements of detached garages in single family residential districts. The intent of the text amendment is to ensure that accessory structures, particularly detached garages, remain accessory to the principal residential use of properties.

He noted comments from the various inter-departmental entities. Engineering did not have a problem with the current setbacks and that the proposed increase in the side and rear yard setbacks will allow more room for utilities.

Public Works and Building and Fire had no comments, but Building and Fire noted that the proposed interior side yard setback modifications are consistent with the code amendments recently approved by the Board in 2004.

"Our shared *Vision* for Lombard is a community of excellence exemplified by its government working together with residents and business to create a distinctive sense of spirit and an outstanding quality of life."

"The *Mission* of the Village of Lombard is to provide superior and responsive governmental services to the people of Lombard."

Mr. Heniff then presented the following amendments from a Planning standpoint. Staff is proposing language to amend the Zoning Ordinance to change the current formulated height of 15' to the "vertical distance measured from the average grade to the highest point on the roof or parapet for any detached accessory building or structure shall not exceed 17 feet."

Staff has seen two-story accessory structures become commonplace and a gambrel or other pitches of roofs could enable the height of the accessory structure to go above the allowable 15' height. This height issue was raised by the Village Board as being inconsistent with the character of the neighborhood. The proposed amended language would be similar to DuPage County's code in that a "not to exceed" number is established. This element would relate to accessory structures and create a gap of 17'. This proposed height would allow people an opportunity to utilize area above their garage for storage purposes but would not create in-law apartment and/or office areas. From a neighborhood standpoint, this would be compatible with the adjacent properties as that it would keep the accessory structures smaller in scope as it relates to height.

Mr. Heniff referred to the standards for the text amendments found on page 3 of the staff report. In summation, staff finds that as more detached garages are becoming two story in design, this was a code issue that should be addressed.

Mr. Heniff then requested comments from the Plan Commissioners relative to the height of accessory structures.

Commissioner Flint stated the proposed height regulation was reasonable and would allow storage above the garage.

Chairperson Ryan referred to the illustration shown on page 2 of the staff report, which shows 8' to the roof. He questioned the standard of the garage door opening and how garages are getting larger to accommodate larger vehicles. He was concerned that if developers starting making garage doors larger, the 17' limit could be insufficient. Mr. Heniff stated the proposed height would still be sufficient as builders could make it work by modifying the pitch of the roof and also by having a "not to exceed" number which could provide flexibility.

Commissioner Burke asked if the sketch was part of the proposed amendment. Mr. Heniff indicated that it would not be but was included for illustrative purposes. Commissioner Burke stated that 8' is not standard anymore. Architecturally, it could be grim, but from a storage standpoint, it could be worse. He recalled from previous discussions that some of the dimensions from surrounding communities were higher than 17'. Mr. Heniff stated that there were some higher, but those heights hinged on other variables. Staff felt that 17' was a good compromise to allow storage but not to create a room.

Commissioner Sweetser asked for a recalculation to see how a typical garage would look with a 10' clearance with the same type of roof pitch. She then stated she would be willing to go with a "no higher than" number but is not sure if that would be satisfactory to staff.

Chairperson Ryan stated his concern was that the proposed amendment would include the accommodation of bigger vehicle trends but also be limiting architectural components by only being able to have a flat roof. He then deferred to Commissioner Flint for his opinion.

Commissioner Flint stated that he was comparing this proposed height amendment to his garage. He stated that they have a tight fit. He indicated they have a 12/12 slope, the cross bracing requires you to duck to get through, and they have a 7' garage door. He indicated that if you wanted an oversized vehicle you would have to have an additional foot for clearance. If that were the case, it would be tough to walk up there.

Mr. Heniff then continued to the second proposed amendment, which is Area Requirements for Accessory Buildings and Structures. He mentioned this was previously introduced and that a 1,000 foot accessory structure could be construed as being rather sizeable and taking up too much of the property. When this issue was previously brought forward in 2002 by staff, there was no cap on the size of the accessory structure. Concerns by the public and questions by the Village Board indicated that the 1,000 square foot cap is still too permissive and that a 750 square foot limit is being proposed. He referred to a sample text amendment to ground floor area, which could be found in the staff report. He stated that 750' is 10 percent of the zoning lot or 750 square feet in ground floor area, which would still allow for three cars. The 1,000 cap could be conducive to other activities that are not permitted by code such as home occupations or other storage issues. One of the concerns raised at the workshop was that the 1,000 square foot cap would allow for extra storage space, especially if you had a smaller home. Staff believes this new area amendment would still allow for three vehicles within the 750', and should more space be required, an addition to the home might be a solution or to attach the garage to the home.

He stated that staff did meet the standards for text amendments based on the 750' provision and requested comments/discussion by the Plan Commissioners.

Commissioner Sweetser asked if staff considered what would happen if a lot width variation was granted in an R2 to be narrower than 60' and the possible impact that might have on the 750 square foot limit or 10 percent of the buildable lot. Mr. Heniff stated that there are other controlling factors such as open space, setbacks, and other bulk requirements that would affect the property more than the 750 square foot provision.

Commissioners Burke and Sweetser questioned the wording of the amendment and asked for clarification specifically the 10 percentage versus the 750' cap. Mr. Heniff recited what is existing code and what was being proposed. Chairperson Ryan indicated it might be best to eliminate the percentage factor and just have a 750' cap, as the wording was confusing. Commissioner Sweetser concurred to leave it as just a number and not have the percentage.

Commissioner Burke asked if this amendment was applicable to the other residential districts such as the R3. Mr. Heniff indicated this amendment was specific to the residential districts. Chairperson Ryan asked the Commissioners if they concurred with just the 750 cap and no mention of a percentage. The Commissioners agreed.

Commissioner Olbrysh pointed out that this amendment applies to detached garages. He asked if 750 square feet for an attached garage is standard. Mr. Heniff stated that attached garages have an unlimited square footage amount. Commissioner Olbrysh asked what the normal square footage of an attached garage would be. Mr. Heniff stated that it tends to be less and he could provide that information at a later date. Commissioner Olbrysh declined the information and indicated he wanted to know for comparison purposes.

Commissioner Sweetser suggested modifying B1a. by taking out the first sentence and leaving the rest and B1b. to include "detached garages and any single accessory building or structure" and asked if that would reflect the amendment they wanted. Mr. Heniff stated that staff could prepare it in that fashion.

Mr. Heniff indicated that the third item for consideration is the Setback Requirements for Accessory Buildings and Structures. He referred to the suggested amendment in the staff report and stated that staff struck and added a considerable amount of language. Staff proposes that detached accessory buildings or structures that require a foundation, footings or piers shall be set back a minimum of ten feet from the rear property line. All other accessory structures shall be set back a minimum of three feet from the rear property line. For the interior side yard requirements, staff is proposing that detached accessory buildings or structures that require a foundation, footings or piers shall be set back a minimum of five feet from the interior side property line. If an accessory building or structure does not require a foundation, footings, or piers and is located in the rear 25 percent of the lot, the building or structure shall be set back a minimum of three feet from an interior side property line.

This amendment is being proposed to establish uniform development regulations as it relates to the legally permitted location of accessory structures. Currently, accessory structures can be located up to three feet from the property line. Within the Subdivision and Development Ordinance new lots of record require five foot public utility and drainage easements along the interior side lot lines and ten foot easements along the rear lot line. Staff identified cases where adjacent properties have different standards for accessory structures. This amendment proposes to treat all parcels the same regardless of whether easements were recorded on the lot as well as to codify past staff interpretations pertaining to accessory structure location on lots with easements. He referred to the exhibit in the staff report and mentioned that when a plat of subdivision is being done, you are changing the setback regulations for those properties. The need for the easements are still there but are not recorded. Whether recorded or not, staff is proposing that all parcels should be treated equally. He then mentioned staff's interpretation of a temporary structure versus a poured foundation. Mr. Heniff then stated how this amendment would be compatible with the Building Code provisions of having a ten-foot requisite setback as well as addressing concerns raised as part of previous cases in which it was suggested or required that additional open space be provided between properties. This amendment would move accessory structures away from the property lines.

Mr. Heniff then asked for the Commissioners comments on this amendment.

Chairperson Ryan questioned how much room would be left for a backyard or green space if using this theory and he was concerned about how close a shed would be located to the house for a temporary structure. Commissioner Sweetser clarified that temporary was 3 feet and permanent was 10 feet.

Commissioner Burke agreed with this amendment and felt that it works.

Commissioner Olbrysh agreed and did not have a problem with the amendment but asked to go back to the height amendment. He felt that the text amendment is making the accessory structures dimension more restrictive except for one instance, which is with a flat roof. He asked from a building code standpoint if someone could come in proposing a flat roof. Mr. Heniff stated that it wasn't realistic but theoretically possible.

Commissioner Sweetser referred to the maximum height number and asked if 18' or 19' feet would be out of the question. Mr. Heniff stated that staff could revisit that request and come back to the Plan Commission providing more examples. He also indicated he would get with the Building Department to look at roof pitches and roof heights to find if 17' or 18' might be more appropriate. He will share his findings at the next meeting.

Commissioner Sweetser asked if they could make a motion to approve the petition and incorporate the suggested changes so that this petition would not have to be before the Commissioners again. George Wagner said that due to many issues that need to be addressed, they entertain a motion to continue the petition to the following Plan Commission meeting.

Commissioner Olbrysh stated his concern with the accessory structure height is that the pitch would not be as high, and he agreed with the 17' foot height limit.

Commissioner Sweetser commented that the pitch is a big deal as far as aesthetics.

Commissioner Olbrysh suggested that examples from staff include a lower pitch so they can see what it would look like.

Commissioner Flint wanted to review the height. He indicated that 9' to the eaves leaving an 8' opening, then there would be the beams, and then another foot for the floor and that puts you roughly about 7' from floor to the peak. You will have cross ties 2' below the ties, so you will have 5 feet where you will still have to crouch down and couldn't stand up straight and walk around. If that is what you want people to have then the height needs to be raised up. It would be doable but not comfortable. Mr. Heniff stated that was staff's intention - to give people the capacity for storage but not making it so attractive to become a room.

After due consideration of the petition and testimony presented, the Plan Commission found that additional research and discussion regarding the petition, particularly as it related to garage heights, would be beneficial. Therefore, the Plan Commission, by a roll call vote of 5 to 0, to continue the hearing to the June 21, 2004 Plan Commission meeting.

June 21, 2004

William Heniff, presented a supplemental staff report. He summarized the discussion of the previous meeting and indicated that staff had addressed the concerns of the Plan Commissioners at the last meeting by providing additional information for their consideration.

In response to the comments that were specifically raised by the Commissioners at the last Plan Commission meeting relative to garage height, he provided three examples of different garage heights and rooflines. Mr. Heniff indicated that he reviewed building permits issued in 2003 and selected three garages that reflect how the code amendments would affect garage styles. These plans are being presented to show the range of garage types found in the Village.

The first plan showed the traditional gable roof - a one-story garage design having standard elevations and includes the issue with the ties. The second plan showed the other extreme where the builder chose a gambrel roof, also known as a barn roof, to maximize space on the second level. This plan shows the ties, truss and the substantial amount of space on the second level. Staff is concerned that this space could allow for an in-law apartment or a home occupation. If the overall garage height was capped at 17 feet, it would decrease the clearance height for the second level. The overall square footage of the depicted garage is 936 square feet, which is at the high end of the code. This accessory structure almost equals the residential structure.

The third example indicates a gable roof with a high peak. If the 17-foot maximum height limit was applied, it would decrease the roof pitch. Staff does not believe it would be inconsistent with the house design as it still allows the ability for architectural embellishments to be added.

Chairperson Ryan then opened the meeting for public comment. No was no one in the audience speaking in favor or in opposition to the petition.

Chairperson Ryan opened the meeting for discussion among the Plan Commission members.

Commissioner Burke questioned how one would bring the garage in example three into compliance. Mr. Heniff answered that the roof pitch would need to be modified. This change would still have a greater roof pitch than compared to a 12/4 roof pitch in the first example.

Commissioner Burke stated that he thought the most attractive garage was the one represented in example 3, which has a height of 20.5 feet. He stated that if you bring the height down to 17 feet it would look like example one.

Commissioner Flint stated that if you drop the roofline, you could drop the ceiling line, which is unusually high. Mr. Heniff stated that you could drop it another foot and a half. Commissioner Flint indicated that would reduce the height.

Commissioner Flint indicated that at the last meeting, he shared his garage experience and has measured it. His garage has a 16' 3" height and an 8'6" floor to ceiling height on the first level.

The pitch of the roof is 8/12. His garage design is very close to what we are talking about restricting to 17 feet. It is doable for storage but does not provide for office space.

Commissioner Sweetser asked if these figures were absolutes or could a resident apply for a variation. Mr. Heniff stated they could apply for a variation. Commissioner Sweetser agreed with Commissioner Burke in that the picture presented in example three is very attractive and wants the process to remain as an option.

Commissioner Olbrysh indicated that he likes the 17-foot height restriction.

Commissioner Burke stated that he thought the height should be higher as he did not want to see variances for an 18-foot high garage.

Mr. Heniff indicated that the staff report also provided additional information regarding the setback requirements as well as having the overall percentage being eliminated. He confirmed that they selected 750 square feet with an absolute formula.

Commissioner Melarkey asked how many garages were permitted over 750 square feet in size. Mr. Heniff answered maybe 15 to 20. Commissioner Melarkey asked how many of those were for properties over 7,500 square feet. Mr. Heniff said that staff did not research this issue.

Commissioner Melarkey asked if 750 square feet would accommodate a three-car garage. Mr. Heniff answered that it would.

After due consideration of the petition and the testimony presented, the Plan Commission found that the proposed text amendments do comply with the standards of the Lombard Zoning Ordinance. Therefore, the Plan Commission, by a roll call vote of 6 to 0, recommended to the Corporate Authorities, approval of the petition associated with PC 04-17.

Respectfully,

VILLAGE OF LOMBARD

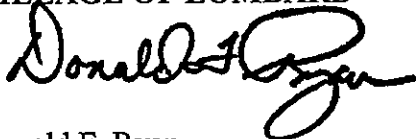

Donald F. Ryan
Chairperson
Lombard Plan Commission

WJH:
att-

c Petitioner
Lombard Plan Commission

VILLAGE OF LOMBARD
INTER-DEPARTMENTAL REVIEW GROUP REPORT

TO: Lombard Plan Commission

HEARING DATE: June 21, 2004
(continued from the May 17, 2004 meeting)

FROM: Department of Community
Development

PREPARED BY: William J. Heniff, AICP
Senior Planner

TITLE

PC 04-17; Text Amendment to the Lombard Zoning Ordinance: The Village of Lombard requests a text amendment to Section 155.210 of the Lombard Zoning Ordinance to modify the maximum permitted height, yard requirements and overall maximum size of accessory buildings and structures.

BACKGROUND:

The Planning Services Division of the Community Development Department is proposing changes to the Zoning Ordinance as it pertains to the maximum allowable height, size and yard requirements of detached garages in single family residential districts. The amendments are in response to previous Village Board and Plan Commission workshop sessions. The proposed amendments are also intended to ensure that accessory structures, most notably detached garages, are clearly accessory to the principal single-family residential use of properties.

At the May 17, 2004 Plan Commission meeting, staff presented draft text amendments for Plan Commission consideration. The Plan Commission continued the matter to address issues raised at the meeting. Additional information regarding each of these items discussed at the Plan Commission meeting is noted below. A copy of the previous report provided to the Plan Commission is also attached for your reference. Each section concludes with the latest version of the proposed text amendments that includes the initial Plan Commission suggestions as well. To fully illustrate garage standards, staff is providing the Commissioners with a graphic depicting the existing Building Code requirements for garages and an illustrative example of the various roof styles. Staff will be also presenting illustrative examples at the Plan Commission meeting.

Height of Accessory Buildings and Structures

May 17, 2004 Plan Commission Follow-Up Questions

- *Standards for garage door openings and how they may be getting larger to accommodate larger vehicles. If garage doors become larger, the 17 foot height limit may be insufficient.*

Staff Response

Staff believes that the seventeen foot height maximum still allows for flexibility if the garage walls are erected at a nine or ten foot height. This can be accomplished by reducing the roof pitch or decreasing the overall width of the garage. Staff also believes that the limitation could be justified as it can be used as a check against individuals who may use their garages for home occupation uses. Oversized doors can sometimes be used as a “red flag” for Planning staff. However by limiting the height on the second level would help ensure that a full business operation or a secondary dwelling unit does not occupy the garage.

- *What is the standard height for garages – eight foot height limit is not standard anymore and that having a 9' dimension will cause the space to shrink. From a storage standpoint, this could be quite limiting. Other communities had regulations that are higher than 17 feet.*

Staff Response

In discussions and review of recent garage permits, approximately 80 percent of new detached garages have been of a standard design (eight foot walls). Staff believes that the limitation can still provide storage space, but it will limit active use of the second level. Property owners still have the ability to expand onto their principal structure – this change only refers to accessory detached garages. Rafter areas will still need collar ties and support structures, but staff believes that 17' is a good compromise to allow for storage but not to create full second story rooms.

A list of regulations from other selected communities is provided below.

Jurisdiction	Maximum Height	Height Definition	Additional Regulations
Village Park	15'	Grade to highest structural member	
Wheaton	1.5 stories	Grade to the highest point	
Bensenville	15'	Grade to the highest point	
Oak Brook Terrace	16'	Grade to the highest point	Sheds cannot be more than 10' above grade
Carol Stream	15'	Grade to highest point	
Woodridge	17'	Grade to the highest point	
Naperville	18'	Grade to the highest point	
Downers Grove	20'	Grade to the highest point	
Elmhurst	21'	Grade to the highest point	Gable and hip roofs only, gambrel roof permitted where principal structure has gambrel roof
Glen Ellyn	22'	Grade to the highest point	15' maximum ht. for gazebos and sheds
DuPage County	24'	Grade to the highest point	
Oak Brook starting 1/27/04	25'	Grade to the highest point	Continuous flat roof no higher than 15'. Each additional ft. over 15' has to increase set back by 1'
Darien	14'	Mean height calculation	12' maximum ht. for gazebos and sheds
Bartlett	15'	Mean height calculation	
Lombard	15'	Mean height calculation	
Roselle	15'	Midpoint of rafter	
West Chicago	15' 6"	Mean height calculation	Garage must have a service door
Winfield	17'	Mean height calculation	
Glaendon Hills	20'	Mean height calculation	
Westmont	24'	Mean height calculation	Sheds are maximum 15' high and 10' from other accessory structures.

- *How would a typical garage would look with a 10' clearance with the same type of roof pitch. Has there been any consideration to go with a "no higher than" number? Is not sure if that would be satisfactory to staff?*

Staff Response

Staff will be providing examples at the Plan Commission meeting. The 17-foot limitation is intended to make sure that detached structures do not overwhelm a property or a neighboring property. Staff still believes that the height limitation does not unduly limit a property owner – substantial flexibility still exists below the 17 foot line.

- *Would the text amendment limit architectural components by only being able to have a flat roof?*

Staff Response

The regulation could increase the number of garages with lower roof pitches. BIS finds that many garage roofs are constructed at a 4/12 pitch. The proposed amendment could still allow for higher roof pitches (i.e., 6/12). Alternatively, owners could also select an alternative roof pitch style (e.g., gable, hip, gambrel, mansard, etc.) to meet their needs instead of a standard flat roof.

Interestingly, many of the garage builders in the community (i.e., Blue Sky, Danley) have incorporated the Village's specifications into their prototype design plans.

- *Would the code change promote more flat roofs?*

Staff Response

While that is theoretically possible, the Building Division notes that flat roofs are generally undesirable as the structural members of the roofs must be able to accommodate snow loads. Right now, Village codes allow for flat roofs for garages, however the loading limitation required for flat roofs have made this design less desirable.

- *Is 17 feet the most desirable - is 18 or 19 feet out of the question?*

Staff Response

BIS reviewed this issue and finds that the 17 foot limitation as being a reasonable limit based upon what we are trying to accomplish. Per the request of the Commissioners, staff will be providing more examples as to how the 17 foot provision can be met while still providing for storage area.

Suggested Amendments

3. Height of Accessory Buildings and Structures

Unless otherwise provided for in this ordinance, the height of accessory buildings and structures shall meet the following requirements:

- a. No detached accessory building or structure shall exceed the height of the principal structure or use, ~~or~~ and
- b. ~~No detached accessory building or structure shall exceed a height of 15 feet, whichever is lower.~~ The vertical distance measured from the average grade to the highest point on the roof or parapet for any detached accessory building or structure shall not exceed seventeen (17) feet.

Area Requirements for Accessory Buildings and Structures

May 17, 2004 Plan Commission Follow-Up Questions

- What are the impacts of the 750 square foot limit or 10 percent of the buildable lot limit on lots narrower than 60'.

Staff Response

Staff notes that the 750 square foot limit should be sufficient for a standard R2 lot whether the lot meets code (i.e., 60 feet or greater in width) or is substandard. If an owner of a legal non-conforming lot wants to erect a garage, they can modify their respective plans to reflect the nature of their narrower lot.

- Would it be more desirable to eliminate the percentage factor and just have a 750' cap?

Staff Response

Staff has incorporated this change into the draft amendment. However, staff proposes to keep the ten percent of lot provision for other accessory structures, as deleting these items could have unintended consequences (i.e., limiting the size of decks, pools, etc.) not germane to this issue.

Suggested Amendments

Section 155.210 (B)(1)

B. Restrictions in Residential Districts

The controls over accessory structures and uses described below shall apply only to Residential Districts.

(1) Maximum Area

(a) General Requirements

A single accessory building or structure in a residential district shall not occupy more than 10% of the zoning lot. The combined area of all accessory buildings

and structures shall not exceed the total ground floor area of the principal residence. No accessory use, except for surface parking spaces, shall cover more than 30% of the zoning lot.

(b) Detached Garages

~~In addition to the provisions expressed in Section 155.210(B)(1)(a) above, n~~No building footprint of a detached garage shall exceed ~~1,000~~ seven-hundred fifty (750) square feet in ground floor area on a lot within a R1 or R2 Single-Family Residential District.

Setback Requirements for Accessory Buildings and Structures

May 17, 2004 Plan Commission Follow-Up Questions

- Would this amendment affect other open space provisions in the Ordinance?

Staff Response

This amendment would only affect the location of the structures rather than the lot coverage provisions.

Suggested Amendments

Section 155.210 (B)(2)

2. Yard Requirements

a. ~~General Requirements~~

~~In all residential districts (R1 through R6), accessory structures shall be set back a minimum of three (3) feet from the rear property line and, if the entire structure is located in the rear 25 percent of the lot, accessory structures shall be set back a minimum of three (3) feet from an interior side property line. If any portion of the accessory structure is not located within the rear 25 percent, then a minimum of six (6) foot setback from the interior side property line must be maintained.~~

b. ~~Detached Garages~~

~~In all residential districts (R1 through R6), detached garages shall be set back a minimum of three (3) feet from the rear property line. Detached garages shall be set back a minimum of three (3) feet from the interior side property line and a minimum of twelve (12) feet from the principal structure on any adjoining lot.~~

Unless otherwise provided for in this ordinance, accessory buildings and structures in all residential districts (R1 through R6), shall meet the following requirements:

a. Rear Yard Setback Requirements

Detached accessory buildings or structures that require a foundation, footings or piers shall be set back a minimum of ten (10) feet from the rear property line. All other accessory structures shall be set back a minimum of three (3) feet from the rear property line.

b. Interior Side Yard Setback Requirements

- i. Detached accessory buildings or structures that require a foundation, footings or piers shall be set back a minimum of five (5) feet from the interior side property line.
- ii. If an accessory building or structure does not require a foundation, footings or piers and is located in the rear 25 percent of the lot, the building or structure shall be set back a minimum of three (3) feet from an interior side property line.

RECOMMENDATION:

Based on the above considerations, the Inter-Departmental Review Committee recommends that the Plan Commission make the following motion recommending **approval** of the request as initially proposed and as modified in the Plan Commissioner's comments:

Based on the information and testimony presented, the proposed text amendments comply with the standards required by the Lombard Zoning Ordinance, and, therefore, I move that the Plan Commission accept the finding and recommendation of the Inter-departmental Review Report as the findings of the Plan Commission and therefore, I recommend to the Corporate Authorities **approval** of the text amendments, as amended and described in PC 04-17.

Inter-Departmental Review Group Report Approved By:

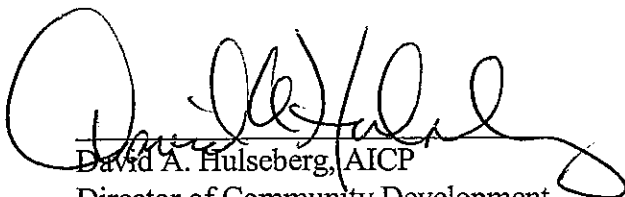
David A. Hulseberg, AICP
Director of Community Development

DAH: WJH

VILLAGE OF LOMBARD
INTER-DEPARTMENTAL REVIEW GROUP REPORT

TO: Lombard Plan Commission

HEARING DATE: May 17, 2004

FROM: Department of Community
Development

PREPARED BY: William J. Heniff, AICP
Senior Planner

TITLE

PC 04-17; Text Amendment to the Lombard Zoning Ordinance: The Village of Lombard requests a text amendment to Section 155.210 of the Lombard Zoning Ordinance to modify the maximum permitted height, yard requirements and overall maximum size of accessory buildings and structures.

BACKGROUND:

The Planning Services Division of the Community Development Department is proposing a change to the Zoning Ordinance as it pertains to the maximum allowable height, size and yard requirements of detached garages in single family residential districts. The amendments are in response to previous Village Board and Plan Commission workshop sessions. The proposed amendments are also intended to ensure that accessory structures, most notably detached garages, are clearly accessory to the principal single-family residential use of properties.

INTER-DEPARTMENTAL REVIEW COMMENTS

ENGINEERING

From an engineering and construction perspective, the Private Engineering Services Division finds that although the current setbacks are not deemed a problem, the proposed increase in the side and rear yard set backs will allow more room for utilities and swales.

PUBLIC WORKS

Public Works has reviewed the petition and does not have any comments.

BUILDING AND FIRE

The Bureau of Inspectional Services has reviewed the petition and does not have any comments. However, they note that the proposed interior side yard setback modifications are consistent with the code amendments recently approved by the Board in 2004.

PLANNING

Three sections included within Section 155.210 are being considered for possible amendments. Each section below will describe the proposed change, explain the rationale for the amendment based upon the standards for text amendments included within the Zoning Ordinance and then offer draft language for consideration. These revisions is also intended to explain the rationale for the regulation and are intended to simplify the regulations per Village Board regulation.

Height of Accessory Buildings and Structures

Suggested Amendments

3. Height of Accessory Buildings and Structures

Unless otherwise provided for in this ordinance, the height of accessory buildings and structures shall meet the following requirements:

- a. No detached accessory building or structure shall exceed the height of the principal structure or use, ~~or~~ and
- b. ~~No detached accessory building or structure shall exceed a height of 15 feet, whichever is lower.~~ The vertical distance measured from the average grade to the highest point on the roof or parapet for any detached accessory building or structure shall not exceed seventeen (17) feet.

As discussed at the December 4, 2003 Village Board meeting and at the February 16, 2004 Plan Commission workshop session, concerns have been raised about the overall height of accessory structures, most notably garages, in single-family residence districts. Specific concerns related to the permitted height formula, which would allow for two-story garages. The concern raised by residents and the Village Board is that the code allows for the erection of garages that may be inconsistent with the intent of the Ordinance, which is to make detached garages clearly subordinate to the principal single-family residence.

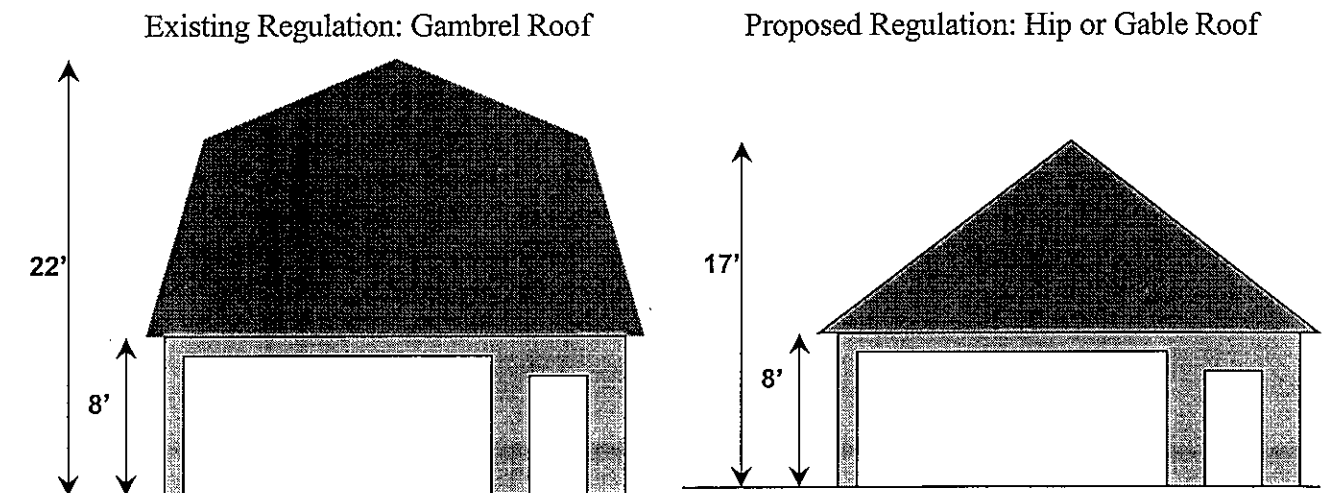

The definition of building height in the Zoning Ordinance states that the calculation of the building height is determined by the mean height for pitched roofs. In the noted gambrel roof example, while the total height of the building exceeds fifteen feet, the formulated height does meet the fifteen foot requirement [$8'$ (wall height) + $22'$ (ridge height) = $30' / 2 = 15'$ **formulated height**]. The proposed code simplified the regulation by stating that no part of the accessory structure shall exceed seventeen feet in height.

Standards for Text Amendments

1. *The degree to which the proposed amendment has general applicability within the Village at large and not intended to benefit specific property*

The proposed amendment would be applicable to all accessory structures regardless of the district. However, the proposed amendment would most frequently be applied as it relates to detached garages in the Village.

2. *The consistency of the proposed amendment with the objectives of this ordinance and the intent of the applicable zoning district regulations*

The proposed Ordinance change is intended to ensure that detached garages are clearly subordinate uses on the property. Garages with gambrel roofs or sizeable second levels can give the appearance that it is a principal building in of itself. By capping the overall height of accessory structures to seventeen feet, the overall bulk of the building will be diminished significantly.

3. *The degree to which the proposed amendment would create nonconformity*

Any structure legally erected in the Village prior to the enactment of this provision would become legal non-conforming structures. Staff is unaware of the total number of garages in the Village that would be come legal non-conforming, but for reference purposes the Village did approve permits for 156 detached garages since October, 2001, of which an estimated 25 were (16%) for two-story garages that would likely exceed the new code provisions.

4. *The degree to which the proposed amendment would make this ordinance more permissive*

The amendment is intended to increase the development regulations on accessory structures. Under the current code, the formulated building height of fifteen feet allows for structures of height greater than fifteen feet when the pitched roofs are added to the equation. The proposed amendment will not allow any structure to extend beyond seventeen feet. Therefore, the proposed regulation will result in smaller second story areas and would relegate many of these areas to being used for storage uses only. The amendment would only be more permissive if an accessory structure were to have a flat roof. However, this has not been common development practice in the Village and flat roofs are generally undesirable from a building code standpoint as the structural requirement of structures with flat roofs are much greater.

5. *The consistency of the proposed amendment with the Comprehensive Plan*

The proposed amendment would be consistent with the Comprehensive Plan as it would ensure that the accessory structures would remain ancillary. Moreover, the amendment would also help ensure that secondary uses on the property (i.e., business occupations, second residences, etc.) are not being created on the respective properties.

6. *The degree to which the proposed amendment is consistent with Village policy as established in previous rulings on petitions involving similar circumstances.*

This amendment would be consistent with past Village Board actions that have attempted to ensure that accessory structures are clearly subordinate on the property.

Area Requirements for Accessory Buildings and Structures

Suggested Amendments

Section 155.210 (B)(1)

B. Restrictions in Residential Districts

The controls over accessory structures and uses described below shall apply only to Residential Districts.

(1) Maximum Area

(a) General Requirements

A single accessory building or structure in a residential district shall not occupy more than 10% of the zoning lot. The combined area of all accessory buildings and structures shall not exceed the total ground floor area of the principal residence. No accessory use, except for surface parking spaces, shall cover more than 30% of the zoning lot.

(b) Detached Garages

In addition to the provisions expressed in Section 155.210(B)(1)(a) above, no building footprint of a detached garage shall exceed ~~1,000~~ seven-hundred fifty (750) square feet in ground floor area on a lot within a R1 or R2 Single-Family Residential District.

In consideration of the accessory height issue, the Village Board also requested that staff examine the overall permitted size of accessory structures as well. Concerns have been expressed by the Board that state that the 1,000 square foot cap on accessory structures may still be too permissive

and may be inconsistent with neighborhood character. Moreover, as with the height provisions, very large accessory structures are conducive to other activities that are not permitted by code such as home occupations or business storage uses within such structures.

The proposed amendment is intended to cap the overall square footage at 10% of the zoning lot or 750 square feet, whichever is lower. The limit of 750 square feet limitation also calculates to be ten percent of the 7,500 square foot minimum lot size in the R2 District. While concerns have been expressed that this may be too limiting on property owners, staff notes that a 750 square foot garage can easily accommodate three motor vehicles and some storage space. If one needs more space than permitted by code, they could erect an addition to their residence.

Standards for Text Amendments

1. *The degree to which the proposed amendment has general applicability within the Village at large and not intended to benefit specific property*

The proposed amendment would be applicable to all accessory structures in the R1 and R2 residence districts.

2. *The consistency of the proposed amendment with the objectives of this ordinance and the intent of the applicable zoning district regulations*

The proposed Ordinance change is intended to ensure that detached accessory structures are clearly subordinate to the principal residence and are used as such.

3. *The degree to which the proposed amendment would create nonconformity*

Any structure legally erected that is over 750 square feet in size would become legal non-conforming structures. Staff is unaware of the total number of garages in the Village that would become legal non-conforming. However, staff estimates that the number would be slightly higher than the number of two-story garages found in the Village.

4. *The degree to which the proposed amendment would make this ordinance more permissive*

The amendment would make the code more restrictive as it would decrease the overall size of such structures.

5. *The consistency of the proposed amendment with the Comprehensive Plan*

The proposed amendment would be consistent with the Comprehensive Plan as it would ensure that the accessory structures are located on properties in a manner that does not negatively impact abutting properties and would ensure that the garages are clearly subordinate to the principal residence.

6. *The degree to which the proposed amendment is consistent with Village policy as established in previous rulings on petitions involving similar circumstances.*

The Village Board has previously approved modifications to the overall size restrictions in 2002 (PC 02-20). This amendment is a further refinement of this provision.

Setback Requirements for Accessory Buildings and Structures

Suggested Amendments

Section 155.210 (B)(2)

2. Yard Requirements

a. ~~General Requirements~~

~~In all residential districts (R1 through R6), accessory structures shall be set back a minimum of three (3) feet from the rear property line and, if the entire structure is located in the rear 25 percent of the lot, accessory structures shall be set back a minimum of three (3) feet from an interior side property line. If any portion of the accessory structure is not located within the rear 25 percent, then a minimum of six (6) foot setback from the interior side property line must be maintained.~~

b. ~~Detached Garages~~

~~In all residential districts (R1 through R6), detached garages shall be set back a minimum of three (3) feet from the rear property line. Detached garages shall be set back a minimum of three (3) feet from the interior side property line and a minimum of twelve (12) feet from the principal structure on any adjoining lot.~~

Unless otherwise provided for in this ordinance, accessory buildings and structures in all residential districts (R1 through R6), shall meet the following requirements:

a. Rear Yard Setback Requirements

Detached accessory buildings or structures that require a foundation, footings or piers shall be set back a minimum of ten (10) feet from the rear property line. All other accessory structures shall be set back a minimum of three (3) feet from the rear property line.

b. Interior Side Yard Setback Requirements

- i. Detached accessory buildings or structures that require a foundation, footings or piers shall be set back a minimum of five (5) feet from the interior side property line.
- ii. If an accessory building or structure does not require a foundation, footings or piers and is located in the rear 25 percent of the lot, the building or structure shall be set back a minimum of three (3) feet from an interior side property line.

This amendment is being proposed in order to establish uniform development regulations as it relates to the legally permitted location of accessory structures. Currently accessory structures can be located up to three feet from property lines in many instances. However, within the Subdivision and Development Ordinance new lots of record require five-foot public utility and drainage easements along the interior side lot lines and ten foot easements along the rear lot line. When put into practice, staff has identified cases whereby adjacent parcels have substantially different regulations as it pertains to setbacks for accessory structures. The proposed amendment is intended to treat all parcels the same regardless of whether easements were officially recorded on the lot.

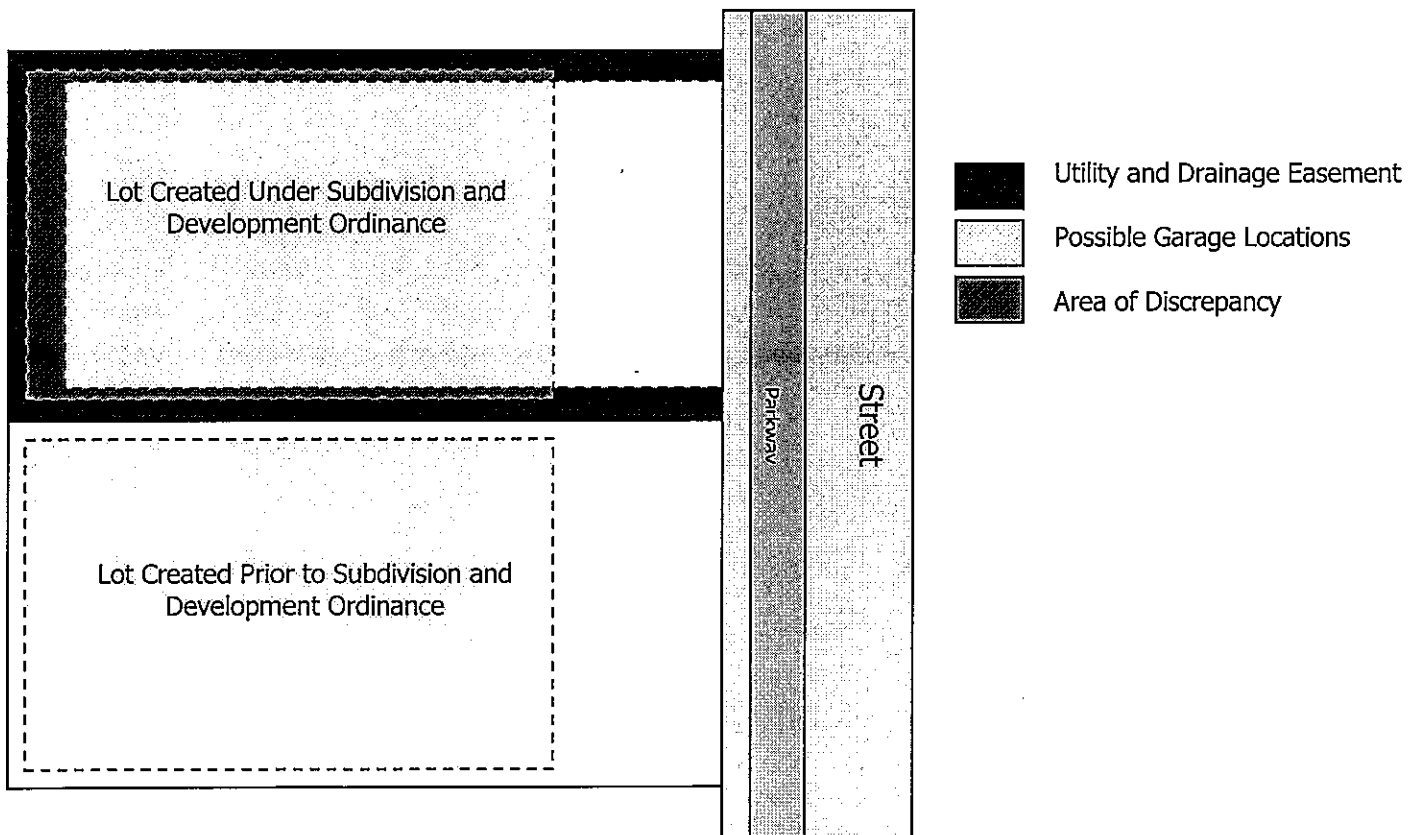

The proposed amendment is also intended to codify past staff interpretations pertaining to accessory structure location on lots with easement. Historically, if a structure was not constructed using a foundation, it was allowed to be placed within an easement area, provided that it was still meeting the three-foot lot line separation requirement. The proposed amendment codifies this interpretation.

Standards for Text Amendments

1. *The degree to which the proposed amendment has general applicability within the Village at large and not intended to benefit specific property*

The proposed amendment would be applicable to all accessory structures in the residence districts. However, the proposed amendment would most frequently be applied as it relates to detached garages in the Village. If enacted the regulations would also apply to any structure on a foundation, footing or pier.

2. *The consistency of the proposed amendment with the objectives of this ordinance and the intent of the applicable zoning district regulations*

The proposed Ordinance change is intended to ensure that detached accessory structures are located on properties in a manner that does not create conflicts with neighboring lots or easements. It is also intended to ensure that sufficient drainage improvements can be constructed in conjunction with these structures.

3. *The degree to which the proposed amendment would create nonconformity*

Any structure legally erected within the area subject to the amendment would become legal non-conforming structures. Staff is unaware of the total number of garages in the Village that would be come legal non-conforming.

4. *The degree to which the proposed amendment would make this ordinance more permissive*

The amendment is intended to increase the setback regulations on accessory structures in some cases, but relax the standards in others. Under the proposed code, all detached structures requiring a foundation, footing or pier would need to be at least five feet from the side property line and ten feet from the rear property line. For lots with full recorded easements, no substantial regulatory change would occur. However, for lots without recorded easements, the setbacks would be the same as those required for newly platted lots.

The current regulations allow for garages up to three feet from the property line regardless of how far they are set back on the property. Sheds can be three feet from the property line only if they are in the rear 25 percent of the lot, otherwise a six foot setback is required. The proposed amendment

would establish a uniform five-foot setback for all detached accessory structures that are on foundations, footings or piers. Other structures can be three feet from the property line.

5. *The consistency of the proposed amendment with the Comprehensive Plan*

The proposed amendment would be consistent with the Comprehensive Plan as it would ensure that the accessory structures are located on properties in a manner that does not negatively impact abutting properties. It also establishes more uniform regulations throughout the community.

6. *The degree to which the proposed amendment is consistent with Village policy as established in previous rulings on petitions involving similar circumstances.*

This amendment would be consistent with past Village Board actions that have attempted to ensure that accessory structures do not negatively impact abutting properties. The proposed modifications are consistent with the ten-foot requisite setback provisions included as part of the Building Code amendments this year. The increase also address concerns raised as part of previous cases in which it was suggested or required that additional open space be provided between properties.

Additional Discussion

The proposed amendments can be considered independently of one another. However, staff notes that these provisions are related. For example, if the ground floor area is capped at a lower amount, that could affect the corresponding roof pitch of the structure. Additionally, if the second story storage area is deemed to be insufficient, a property owner may look to increase the structure footprint. Therefore, the inter-relationships between these regulations must be considered.

Staff also realizes that these regulations will create a number of nonconforming structures in the Village. However, as these structures are ancillary, as opposed to principal structures, the impacts of the amendments may not be as significant.

RECOMMENDATION:

Based on the above considerations, the Inter-Departmental Review Committee recommends that the Plan Commission make the following motion recommending **approval** of the request as proposed:

Based on the information and testimony presented, the proposed text amendments comply with the standards required by the Lombard Zoning Ordinance, and, therefore, I move that the Plan Commission accept the finding and recommendation of the Inter-departmental Review Report as the findings of the Plan Commission and therefore, I recommend to the Corporate Authorities **approval** of the text amendments described in PC 04-17.

Plan Commission

Re: PC 04-17

Page 10

Inter-Departmental Review Group Report Approved By:

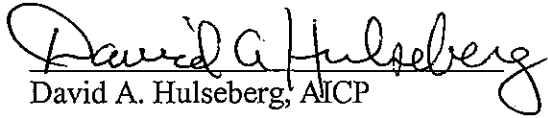

David A. Hulseberg, AICP
Director of Community Development

DAH: WJH

\\hmain2\willage\cdevapps\worduser\pccases\04-17\report.doc

Village of Lombard Garage Minimum Specifications

Submittal Required for Permit:

- 1) Three Copies of Plat of Survey
- 2) Three Complete Sets of Plans Showing: a) Sectional View
b) Elevations of All Four Sides c) Plan View Showing Electrical
- 3) Completed application form

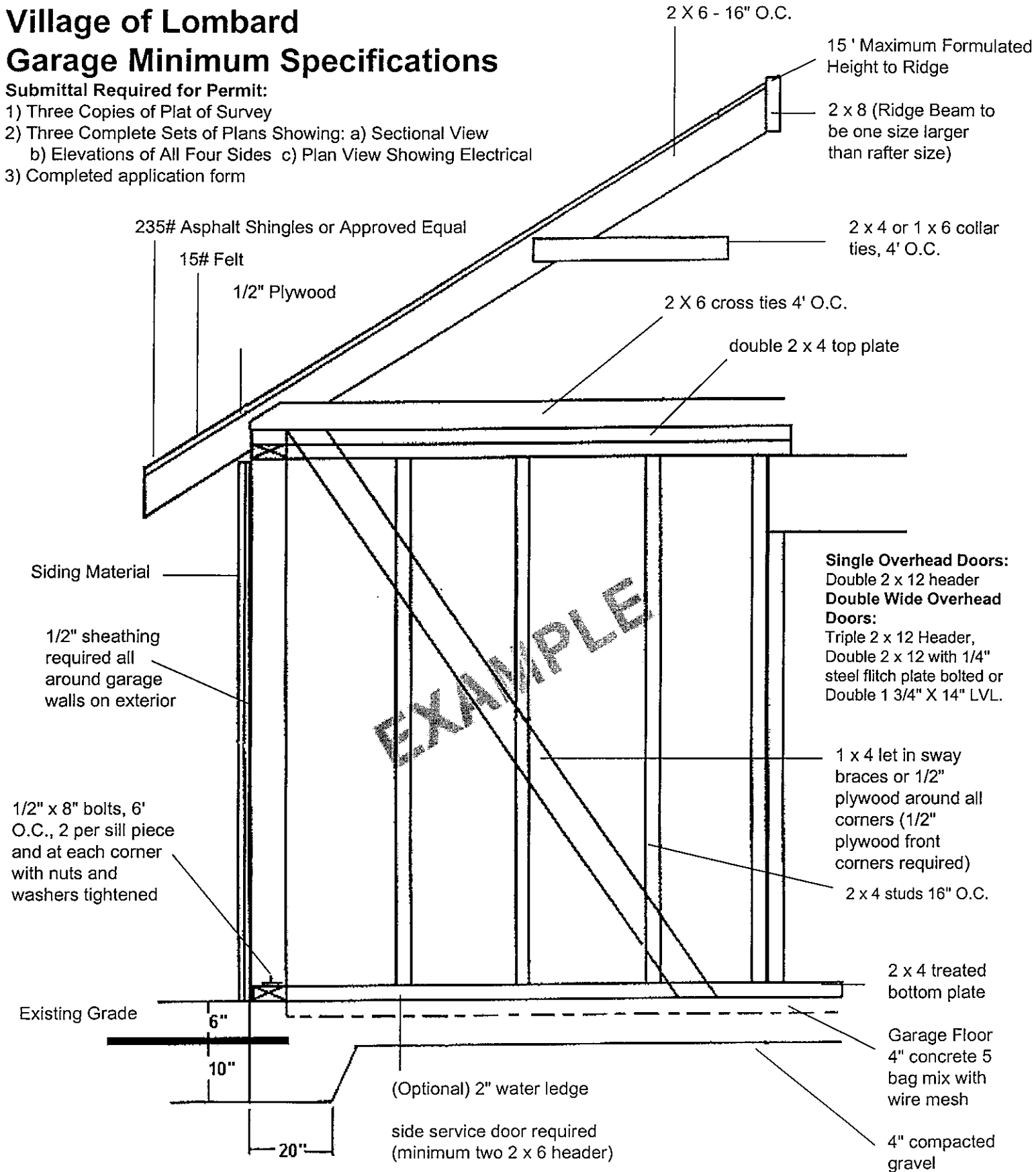

MINIMUM ELECTRIC REQUIREMENTS FOR GARAGES

- 1 each switched entry light at service door
- 1 each switched interior light
- 1 each GFI duplex receptacle

Not drawn to
scale 03/03

BUILDING HEIGHT REQUIREMENTS

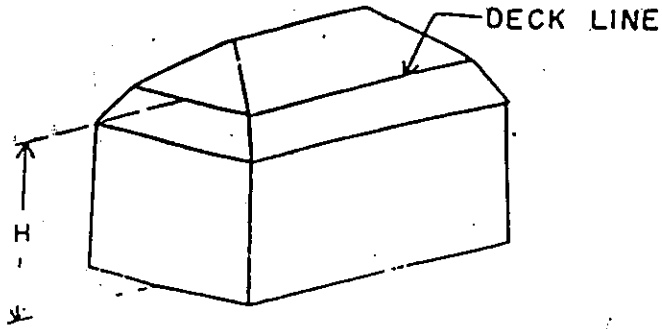

MANSARD ROOF

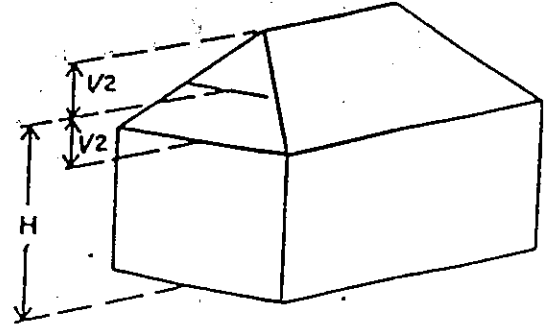

HIP ROOF

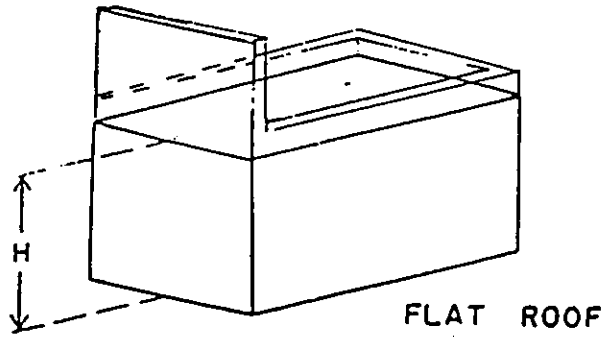

FLAT ROOF

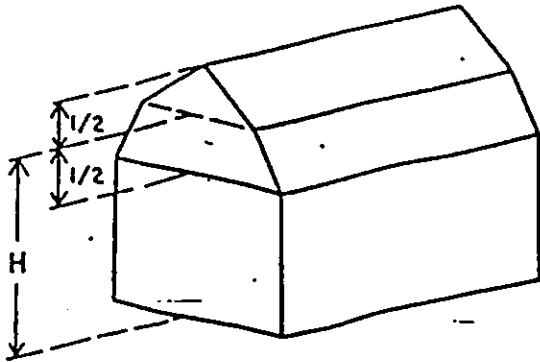

GAMBREL ROOF

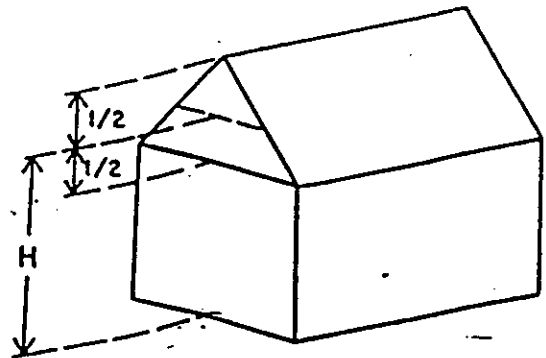

GABLE ROOF

H = HEIGHT OF BUILDING

ORDINANCE _____

**AN ORDINANCE APPROVING A TEXT AMENDMENT
TO THE LOMBARD ZONING ORDINANCE
TITLE 15, CHAPTER 155, SECTION 210 (B) (3)
OF THE CODE OF LOMBARD; ILLINOIS**

(PC 04-17: Accessory Structure Height)

WHEREAS, the Village of Lombard maintains a Zoning Ordinance which is found in Title 15, Chapter 155 of the Code of Lombard, Illinois; and,

WHEREAS, the Board of Trustees deem it reasonable to periodically review said Zoning Ordinance and make necessary changes; and,

WHEREAS, a public hearing to consider text amendments to the Zoning Ordinance has been conducted by the Village of Lombard Plan Commission on May 20, 2004 and June 17, 2004 pursuant to appropriate and legal notice; and,

WHEREAS, the Plan Commission has filed its recommendations with the President and Board of Trustees recommending approval of the text amendments described herein; and,

WHEREAS, the President and Board of Trustees approve and adopt the findings and recommendations of the Plan Commission and incorporate such findings and recommendations herein by reference as if they were fully set forth herein.

NOW, THEREFORE, BE IT ORDAINED BY THE PRESIDENT AND BOARD OF TRUSTEES OF THE VILLAGE OF LOMBARD, DU PAGE COUNTY, ILLINOIS, as follows:

SECTION 1: That Title 15, Chapter 155, Section 210 (B) (3), of the Code of Lombard, Illinois is hereby amended to read in its entirety as follows:

SECTION 155.210 ACCESSORY USES, ACTIVITIES, BUILDINGS, AND STRUCTURES

Section 155.210 (B)(3)

3. Height of Accessory Buildings and Structures

Unless otherwise provided for in this ordinance, the height of accessory buildings and structures shall meet the following requirements:

- a. No detached accessory building or structure shall exceed the height of the principal structure or use, or and
- b. ~~No detached accessory building or structure shall exceed a height of 15 feet, whichever is lower.~~ The vertical distance measured from the average grade to the highest point on the roof or parapet for any detached accessory building or structure shall not exceed seventeen (17) feet.

SECTION 2: This ordinance shall be in full force and effect from and after its passage, approval and publication in pamphlet form as provided by law.

Passed on first reading this ____ day of _____, 2004.

First reading waived by action of the Board of Trustees this ____ day of _____, 2004.

Passed on second reading this ____ day of _____, 2004.

Ayes: _____

Nayes: _____

Absent: _____

Approved this ____ day of _____, 2004.

William J. Mueller, Village President

ATTEST:

Barbara A. Johnson, Deputy Village Clerk

ORDINANCE _____

**AN ORDINANCE APPROVING A TEXT AMENDMENT
TO THE LOMBARD ZONING ORDINANCE
TITLE 15, CHAPTER 155, SECTION 210 (B) (3)
OF THE CODE OF LOMBARD, ILLINOIS**

(PC 04-17: Detached Garage Size)

WHEREAS, the Village of Lombard maintains a Zoning Ordinance which is found in Title 15, Chapter 155 of the Code of Lombard, Illinois; and,

WHEREAS, the Board of Trustees deem it reasonable to periodically review said Zoning Ordinance and make necessary changes; and,

WHEREAS, a public hearing to consider text amendments to the Zoning Ordinance has been conducted by the Village of Lombard Plan Commission on May 20, 2004 and June 17, 2004 pursuant to appropriate and legal notice; and,

WHEREAS, the Plan Commission has filed its recommendations with the President and Board of Trustees recommending approval of the text amendments described herein; and,

WHEREAS, the President and Board of Trustees approve and adopt the findings and recommendations of the Plan Commission and incorporate such findings and recommendations herein by reference as if they were fully set forth herein.

NOW, THEREFORE, BE IT ORDAINED BY THE PRESIDENT AND BOARD OF TRUSTEES OF THE VILLAGE OF LOMBARD, DU PAGE COUNTY, ILLINOIS, as follows:

SECTION 1: That Title 15, Chapter 155, Section 210 (B)(1), of the Code of Lombard, Illinois is hereby amended to read in its entirety as follows:

SECTION 155.210 ACCESSORY USES, ACTIVITIES, BUILDINGS, AND STRUCTURES

Section 155.210 (B)(1)

B. Restrictions in Residential Districts

The controls over accessory structures and uses described below shall apply only to Residential Districts.

(1) Maximum Area

(a) General Requirements

A single accessory building or structure in a residential district shall not occupy more than 10% of the zoning lot. The combined area of all accessory buildings and structures shall not exceed the total ground floor area of the principal residence. No accessory use, except for surface parking spaces, shall cover more than 30% of the zoning lot.

(b) Detached Garages

In addition to the provisions expressed in Section 155.210(B)(1)(a) above, no building footprint of a detached garage shall exceed ~~1,000~~ seven-hundred fifty (750) square feet in ground floor area on a lot within a R1 or R2 Single-Family Residential District.

SECTION 2: This ordinance shall be in full force and effect from and after its passage, approval and publication in pamphlet form as provided by law.

Passed on first reading this ____ day of _____, 2004.

First reading waived by action of the Board of Trustees this ____ day of _____, 2004.

Passed on second reading this ____ day of _____, 2004.

Ayes: _____

Nays: _____

Absent: _____

Approved this ____ day of _____, 2004.

William J. Mueller, Village President

ATTEST:

Ordinance No. _____
Re: PC 04-17 Detached Garage Size
Page 3

Barbara A. Johnson, Deputy Village Clerk

ORDINANCE _____

**AN ORDINANCE APPROVING A TEXT AMENDMENT
TO THE LOMBARD ZONING ORDINANCE
TITLE 15, CHAPTER 155, SECTION 210 (B) (2)
OF THE CODE OF LOMBARD, ILLINOIS**

(PC 04-17: Accessory Structure Locations)

WHEREAS, the Village of Lombard maintains a Zoning Ordinance which is found in Title 15, Chapter 155 of the Code of Lombard, Illinois; and,

WHEREAS, the Board of Trustees deem it reasonable to periodically review said Zoning Ordinance and make necessary changes; and,

WHEREAS, a public hearing to consider text amendments to the Zoning Ordinance has been conducted by the Village of Lombard Plan Commission on May 20, 2004 and June 17, 2004 pursuant to appropriate and legal notice; and,

WHEREAS, the Plan Commission has filed its recommendations with the President and Board of Trustees recommending approval of the text amendments described herein; and,

WHEREAS, the President and Board of Trustees approve and adopt the findings and recommendations of the Plan Commission and incorporate such findings and recommendations herein by reference as if they were fully set forth herein.

NOW, THEREFORE, BE IT ORDAINED BY THE PRESIDENT AND BOARD OF TRUSTEES OF THE VILLAGE OF LOMBARD, DU PAGE COUNTY, ILLINOIS, as follows:

SECTION 1: That Title 15, Chapter 155, Section 210 (B) (2), of the Code of Lombard, Illinois is hereby amended to read in its entirety as follows:

SECTION 155.210 ACCESSORY USES, ACTIVITIES, BUILDINGS, AND STRUCTURES

Section 155.210 (B)(2)

2. Yard Requirements

a. ~~General Requirements~~

~~In all residential districts (R1 through R6), accessory structures shall be set back a minimum of three (3) feet from the rear property line and, if the entire structure is located in the rear 25 percent of the lot, accessory structures shall be set back a minimum of three (3) feet from an interior side property line. If any portion of the accessory structure is not located within the rear 25 percent, then a minimum of six (6) foot setback from the interior side property line must be maintained.~~

b. ~~Detached Garages~~

~~In all residential districts (R1 through R6), detached garages shall be set back a minimum of three (3) feet from the rear property line. Detached garages shall be set back a minimum of three (3) feet from the interior side property line and a minimum of twelve (12) feet from the principal structure on any adjoining lot.~~

Unless otherwise provided for in this ordinance, accessory buildings and structures in all residential districts (R1 through R6), shall meet the following requirements:

a. Rear Yard Setback Requirements

Detached accessory buildings or structures that require a foundation, footings or piers shall be set back a minimum of ten (10) feet from the rear property line. All other accessory structures shall be set back a minimum of three (3) feet from the rear property line.

b. Interior Side Yard Setback Requirements

- i. Detached accessory buildings or structures that require a foundation, footings or piers shall be set back a minimum of five (5) feet from the interior side property line.
- ii. If an accessory building or structure does not require a foundation, footings or piers and is located in the rear 25 percent of the lot, the building or structure shall be set back a minimum of three (3) feet from an interior side property line.

SECTION 2: This ordinance shall be in full force and effect from and after its passage, approval and publication in pamphlet form as provided by law.

Passed on first reading this ____ day of _____, 2004.

First reading waived by action of the Board of Trustees this ____ day of _____, 2004.

Passed on second reading this ____ day of _____, 2004.

Ayes: _____

Nays: _____

Absent: _____

Approved this ____ day of _____, 2004.

William J. Mueller, Village President

ATTEST:

Barbara A. Johnson, Deputy Village Clerk